

COMPANY
PROFILE
2022



ITTEHAD
ALUMINIUM INDUSTRIES



CONTENTS

1.	INTRODUCTION	01
2.	VISION / MISSION / AIM	02
3.	CORE VALUES	03
4.	OUR STRENGTH & PROCESS HIGHLIGHTS	04
5.	BILLET PLANT / EXTRUSION PLANT	05
6.	DIES FACILITIES / ANODIZING PLANT	06
7.	POWDER COATING PLANT / FABRICATION FACILITY	07
8.	UPVC FITTINGS	08
9.	OUR PROJECTS	09
10.	DELUX FIXED GLAZING SECTIONS	13
11.	DELUX DOOR SECTIONS	14
12.	FIXED & OPENABLE DOOR WINDOW SECTIONS	15
13.	FIXED & OPENABLE DOOR SWING SECTIONS	17
14.	DOOR HANDLE SECTIONS / HINGES SECTIONS	18
15.	ECONOMY FIXED GLAZING SECTIONS	19
16.	BOX SLIDING WINDOW SECTIONS	20
17.	COLLAR BOX SLIDING WINDOW SECTIONS	21
18.	COLLAR BOX & ROUND SLIDING WINDOW SECTIONS	22
19.	ET ECONOMY SLIDING WINDOW SECTIONS	23
20.	EC ECONOMY SLIDING WINDOW SECTIONS	24
21.	DOOR STRIP SECTIONS / ECONOMY & BOX SLIDING WINDOW SECTIONS	25
22.	BOX SLIDING WINDOW SECTIONS / CURTAIN WALL SECTIONS	26
23.	CURTAIN WALL SECTIONS	27
24.	KITCHEN SECTIONS	29
25.	BOX DG WINDOW SECTIONS	30
26.	BOX HD FIX 7 DOOR SECTIONS / LOWER SECTIONS	31
27.	PIPE SECTIONS	32
28.	MISCELLANEOUS SECTIONS	33
29.	POWDER COATING COLORS CHART	34
30.	ALU WOOD COLORS CHART	40
31.	CERTIFICATES	43
32.	EXPO 2017	51
33.	EXPO 2018	52
34.	EXPO 2019	53



ITTEHAD

ALUMINIUM INDUSTRIES

INTRODUCTION

Ittehad Aluminum Industries remains the front runner with 16 years of experience in the market of Aluminum in Pakistan. During this period numerous achievements, challenges and obstacles have been experienced that gives our company a rich & diverse knowledge base enjoyed by a pioneer. These experiences are the basic foundation for Ittehad Aluminum Industries to grow and develop into one of the largest player in national Aluminum sector from mainstream to downstream production. In Ittehad Aluminum Industries life, the synergy of integrity, energy and intelligence has become the power of each of Ittehad Aluminum Industries family members and will be inherited from generation to generation as the core work ethic value of our employees. Perfection of taste, kinship and natural working environment has also become a trademark in the work culture in Ittehad Aluminum Industries.



ITTEHAD **ALUMINIUM INDUSTRIES**

VISION

To be a Premier and Integrated company in the Aluminum value chain with strategic presence in both domestic & global, Metals and Energy sectors.

MISSION

To sustainably grow multi-fold in Aluminum business , integrate state of the art procedures , promote diversification, while continuously improving efficiency and business practices ,enhancing value for all stakeholders.

AIM

The aim of Ittehad Aluminum Industries is the most efficient use of Aluminum Materials, effective saving and above all high quality Aluminum product to serve domestic, commercial, government & semi-government sectors . In shaa ALLAH we aim to maintain our lead position in Aluminum Processing Industry.





ITTEHAD
ALUMINIUM INDUSTRIES

CORE VALUES

BENEFITTING STAKEHOLDERS

We provide our customers, suppliers and other stakeholders with utmost level of value, service and satisfaction.

EXCELLENCE AND QUALITY

We ensure that our products, manufacturing & business processes adhere to the highest quality levels and standards.

SUSTAINABILITY

We relentlessly pursue sustainable practices and create a positive impact on the communities we engage with.

TRUST & INTEGRITY

We conduct ourselves with dignity, integrity, equity, transparency and accountability to build trust.





ITTEHAD
ALUMINIUM INDUSTRIES

OUR STRENGTHS & PROCESS HIGHLIGHTS

QUALITY

Sourcing raw materials from world renowned manufacturers ensures only the highest quality products reach end consumers.

SERVICE

From after-sales service to raw material analysis, we strive to achieve the highest level of satisfaction for our growing clientele in various industries.

TRUST

With over three decades of experience we garnered long lasting relationships with customers and principals from the government, semi government & private sector.

MANUFACTURING

Ittehad Aluminum Industries uses superior quality billet, made of alloy 6063. The Billet is internationally acclaimed Aluminum raw material meeting standards of quality Aluminum profiles.

PRODUCTION FACILITY

Our production equipment includes CNC Milling Machines, Conventional Milling Machines, EDM Machines, EDM Wirecut, EDM Drilling, Radial Drilling, etc We have complete in-house Heat Treatment facility that enables us to supply dies in short lead time.



BILLETS PLANT

We use superior quality billet, made of alloy 6063. Our billets are produced in-house to provide highest productivity on our presses, high flexibility on mechanical properties (special alloy) and better quality control. Before casting, the molten metal is treated to ensure it is clean and free of excessive hydrogen contamination. Ittehad Aluminium Industries extrusion ingot is applying only primary aluminium ingot and virtually free of dross or any secondary external scrap. The internal microstructure is modified through a controlled thermal treatment known as homogenizing process. These billets are 100% ultrasonically inspected. This ingenuity and technical expertise is what highlights our unique presence among our competitors.



EXTRUSION PLANT

Our extrusion facility was first established in 2002 with the main focus of manufacturing and distributing a comprehensive range of aluminum sections that are used for commercial, residential and Industrial purposes. It is equipped with complete facilities in billet furnace, extrusion presses, design shop, tool room, surface finishing, fabrication etc and produce high quality aluminum extrusion for global buyers. The Unit design provides and offers a complete solution for the needs of architects, builders and consultants for high class aluminum door, window, partitions and structural glazing etc.





DIES FACILITY

Experience coupled with expertise gives us the edge in the design process. All our dies are designed utilizing the latest computer aided design software. Our designs are based on years of accumulated experience as well as feedback from our clients.

We apply the latest CNC Technology for dies manufacturing.



ANODIZING PLANT

Ittehad Aluminum Industries offers an in-house anodizing and finishing facility where you can get high-performance anodized aluminum profiles and any anodize color (Natural, Brown, Bronze, Champaign, Black, etc) ensuring all products to be delivered in the best possible quality.

Our Caustic Etch anodizing process delivers a superior finish that will last for decades. Ittehad Aluminum Industries in-house facility helps our clients to remain cost-efficient by avoiding scrap overages and freight damage that might incur when working for multiple vendors.





POWDER COATING PLANT

Ittehad Aluminum Industries had been "Approved Applicator" of Jotun, meaning that Ittehad Aluminum Industries is qualified to provide products with warranty requirement such as government & corporation projects. We take pride in our ability to offer widest range of colors to meet the needs and expectations of all our clients.



FABRICATION FACILITY

To keep the competitive edges of all our clients, Ittehad Aluminium Industries provides a specially designed OEM Facility that focus on fulfilling any fabrication requirement of aluminum extrusion profiles. Our facility consist of punching machines, precision cutting machines, CNC routers and other various types of fabrication machines.





UPVC FITTING

When purchasing new or replacement Windows and Doors, it is important you make the right decision on style, frame and material. uPVC, also known as Un-plasticized Polyvinyl Chloride, is a low-maintenance building material used as a substitute for painted wood, mostly for window frames when installing double glazed in new buildings, or to replace older single glazed windows. UPVC material is a cheaper alternative to expensive hardwood timber and aluminium. It is a popular material due to its durability & it being a cost-effective option.





OUR PROJECTS



RED SUN TOWER, GALLERIA,
BAHRIA ENCLAVE.



THE GATE MALL, FAISAL TOWN, ISLAMABAD.



AVARI HOTEL, LAHORE.



DEAN'S HEIGHTS, HAYAT ABAD,
PESHAWAR, KPK.



B R T PESHAWAR, KPK.



I.S.T BUILDING, RAWAT.



OUR PROJECTS



GULISTAN PLAZA, G-13/3 MARKAZ, ISLAMABAD



CENTURY MALL, G-15 MARKAZ, ISLAMABAD



PURAN ARCADE, E-11/2, ISLAMABAD



NATIONAL CONSTRUCTION, H-8 ISLAMABAD



PTCL BUILDING H-9 ISLAMABAD



THE ARCH, G-11/3 ISLAMABAD



OUR PROJECTS



C.M.H Hospital, Rawalpindi



HEADSTART SCHOOL H-11, ISLAMABAD



(OVERSEAS SCHOOL) THE SMART CITY ISLAMABAD.



E-11 MARKAZ, ISLAMABAD



MOHI-UD-DIN ISLAMIC MEDICAL COLLEGE,
MIRPUR, AJK



WOOD COTTAGES NARAN



OUR PROJECTS



H # 982, STREET # 45, BLOCK-B, B-17, ISLAMABAD



H # 46, STREET # 02, SECTOR A, DHA-II, ISLAMABAD



ISLAMABAD.



H # 146, STREET MAIN ROAD 03, G-15/2, ISLAMABAD



H # B.K 831, STREET # 21, I-8/2, ISLAMABAD



ISLAMABAD



ITTEHAD
ALUMINIUM INDUSTRIES

SECTIONS PROFILE



DELUXE FIXED GLAZING SECTIONS

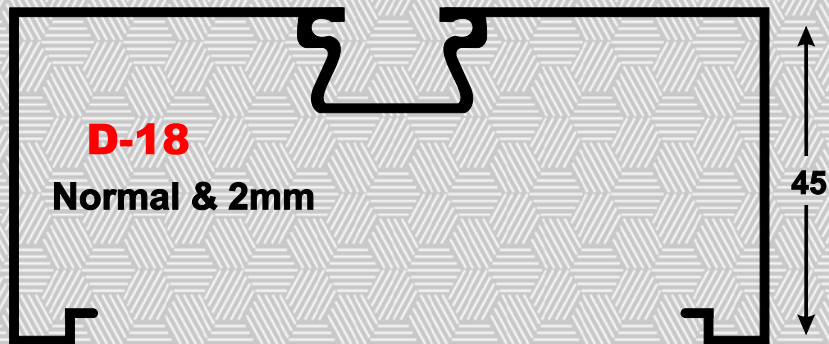
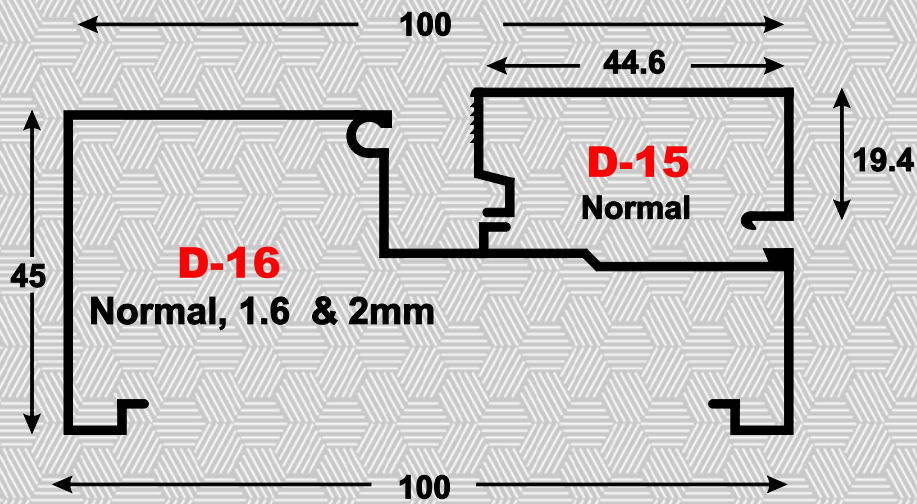
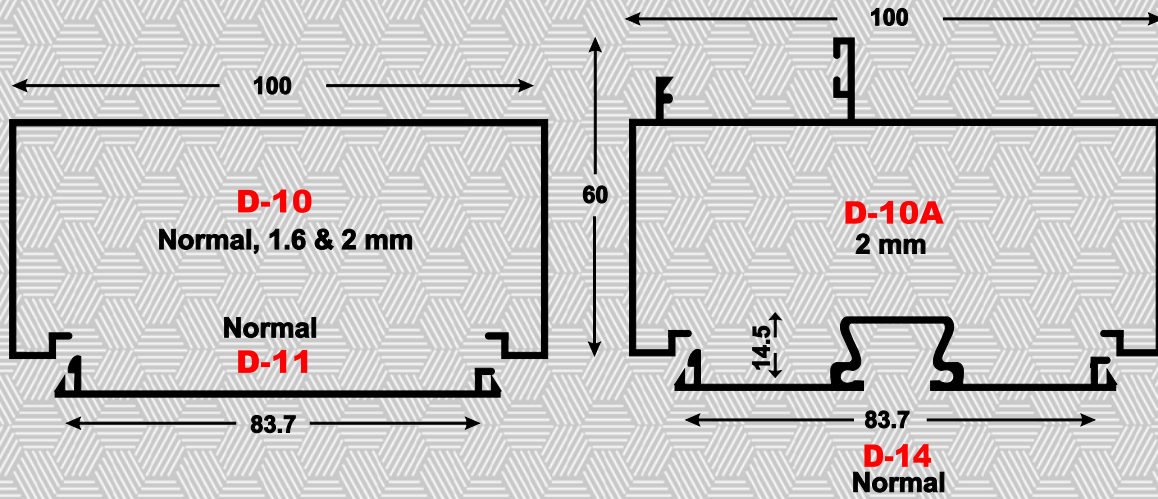



DELUXE DOOR SECTIONS

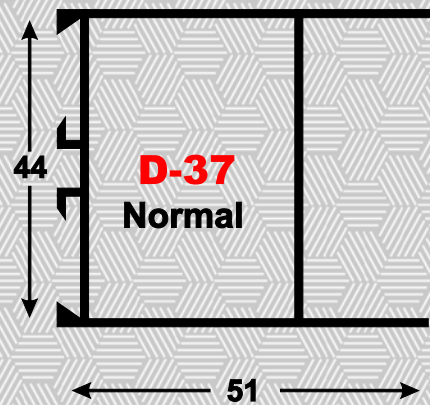
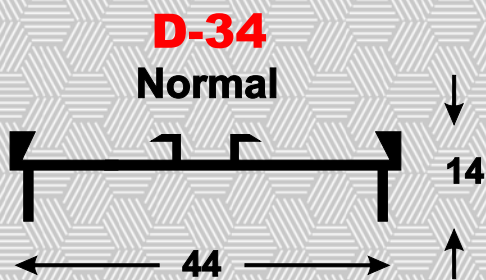
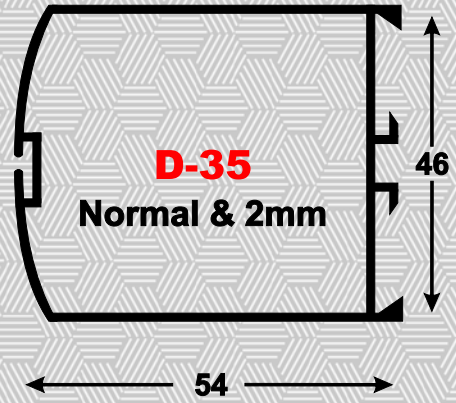
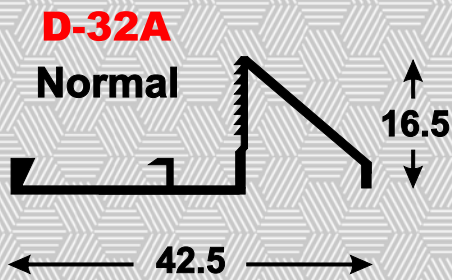
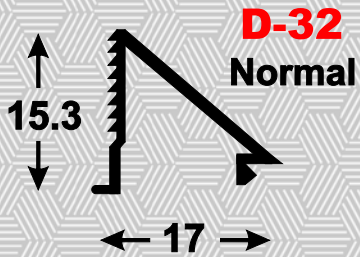
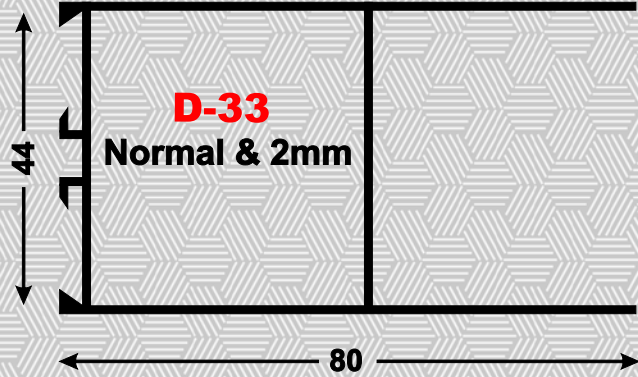
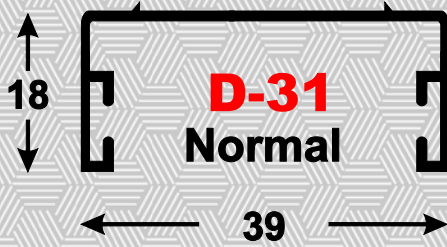

FIXED & OPENABLE DOOR WINDOW SECTIONS

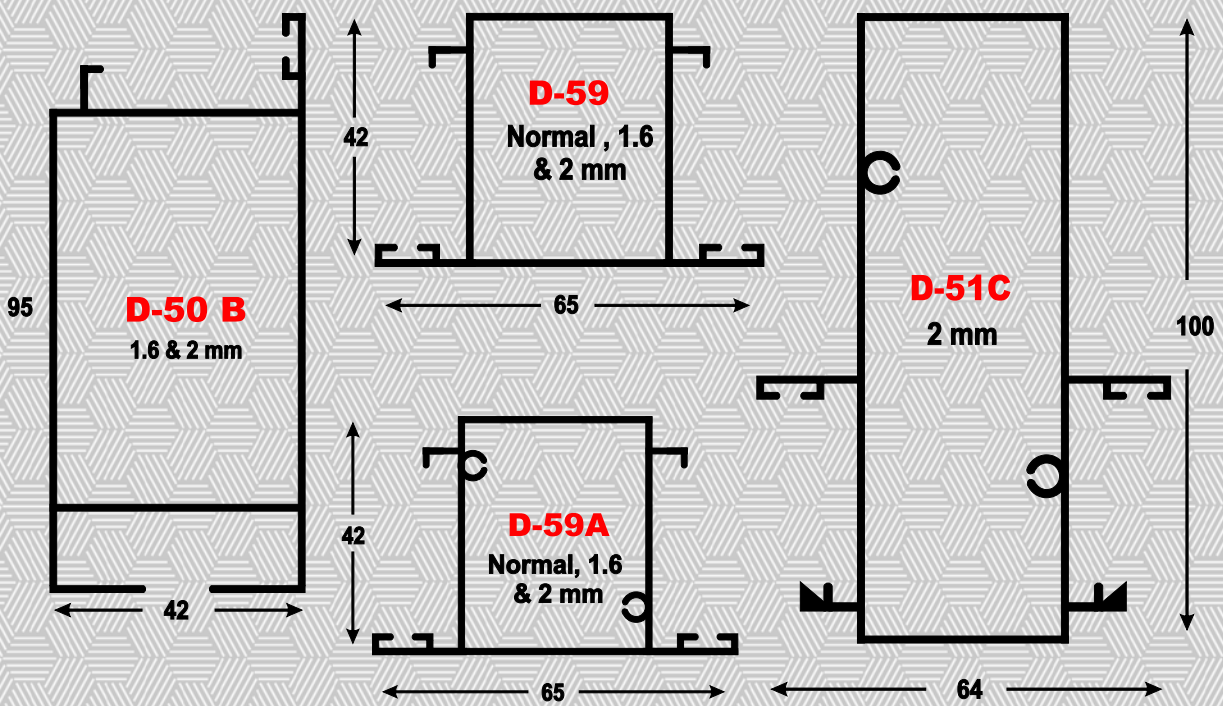
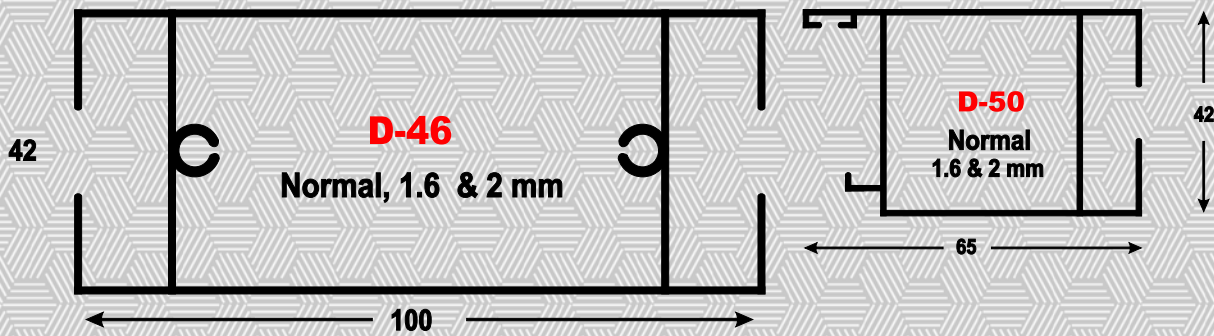
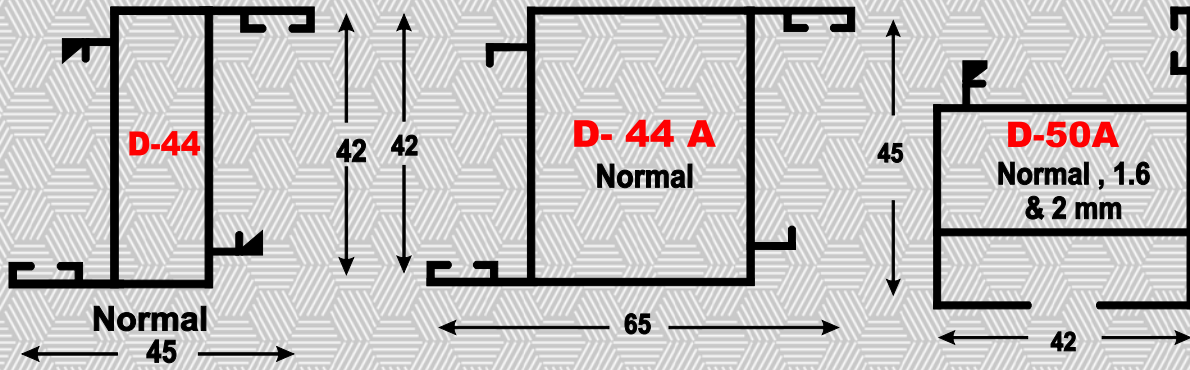

FIXED & OPENABLE DOOR WINDOW SECTIONS

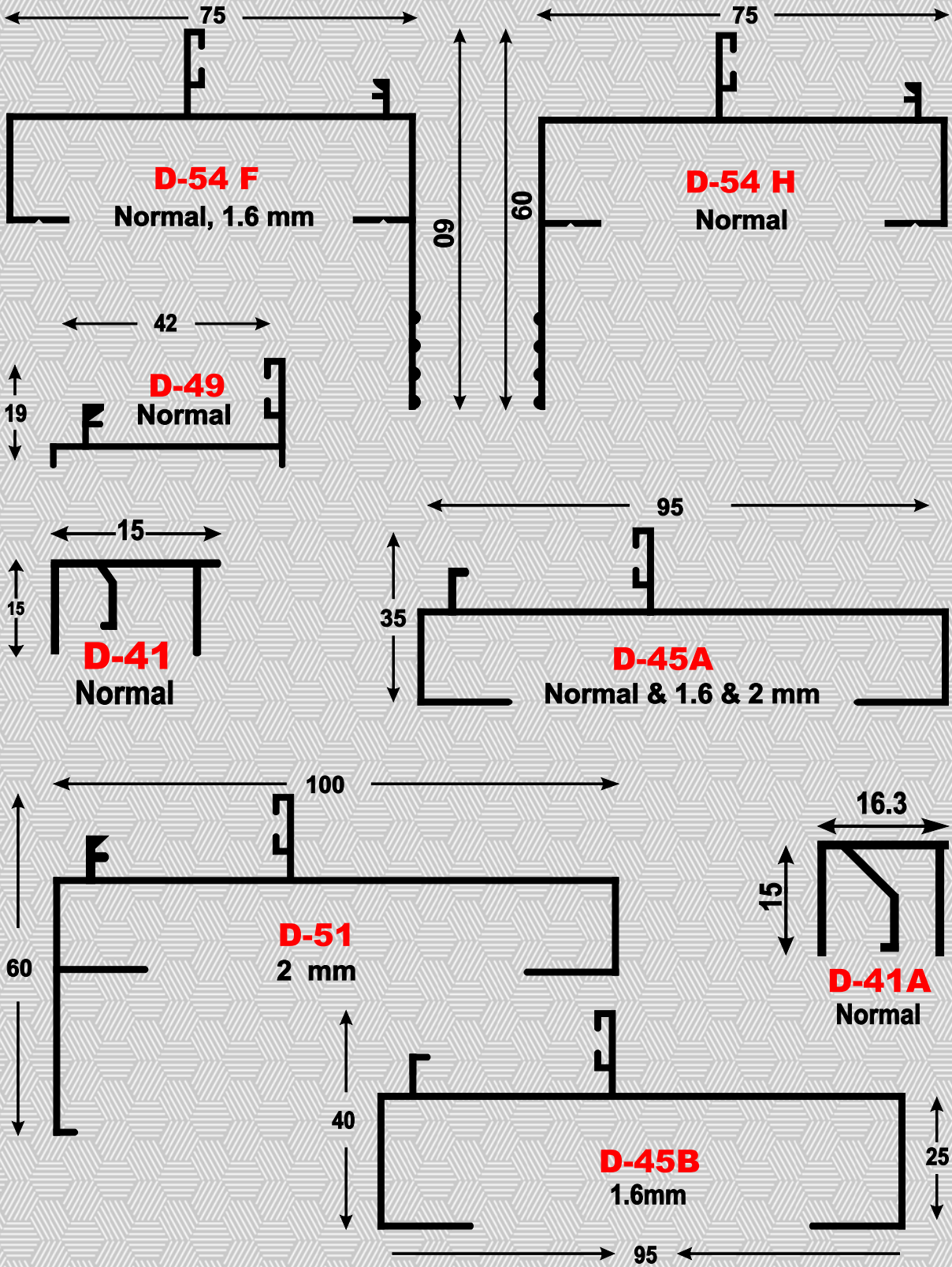



FIXED & OPENABLE DOOR SWING SECTIONS

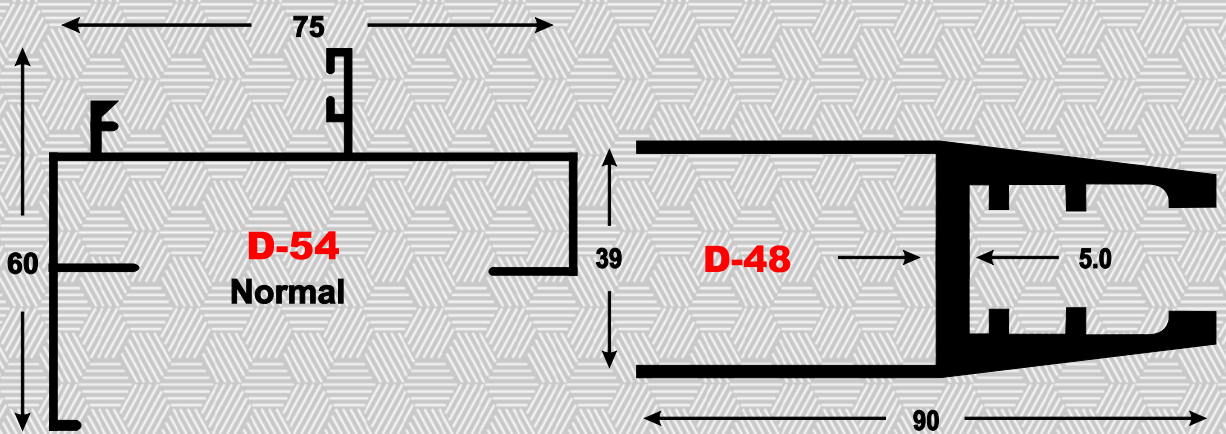
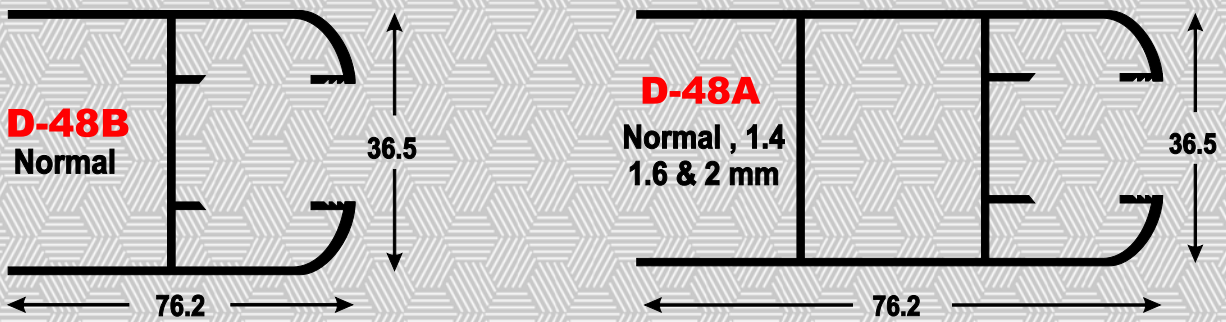
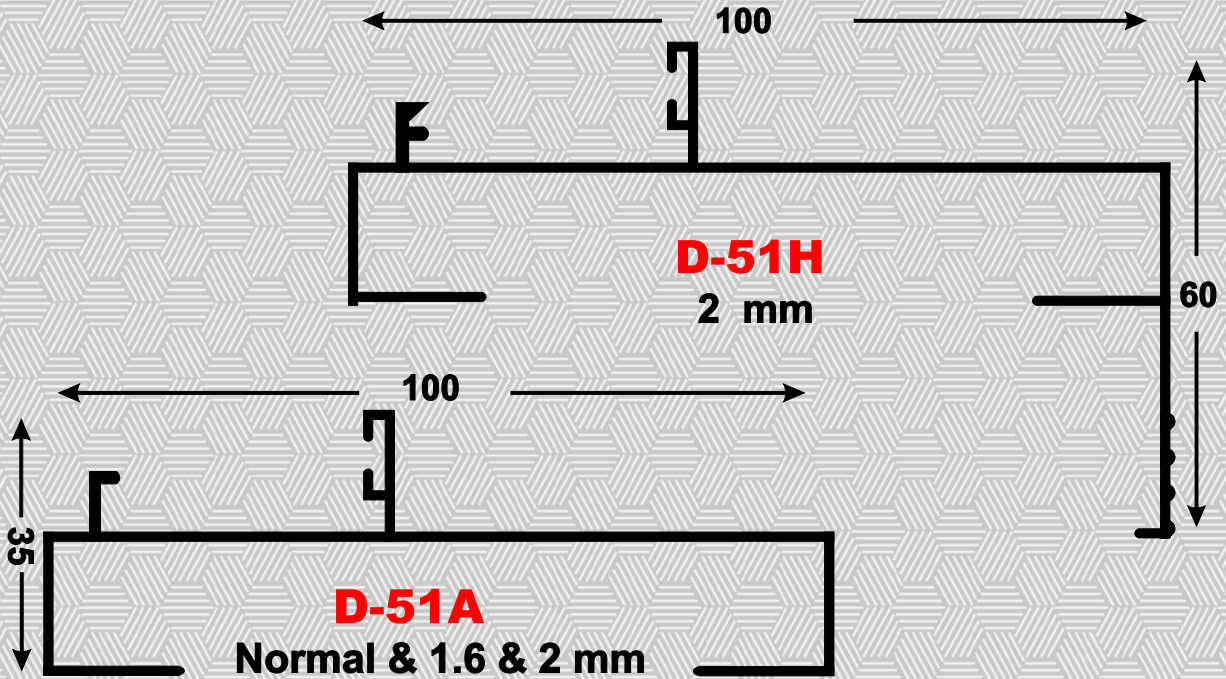



DOOR HANDLE SECTIONS

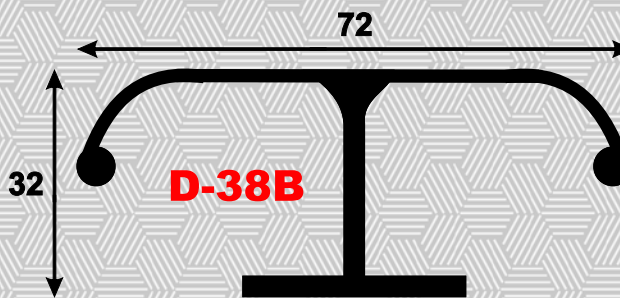
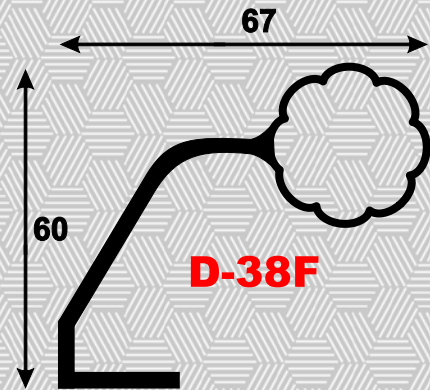
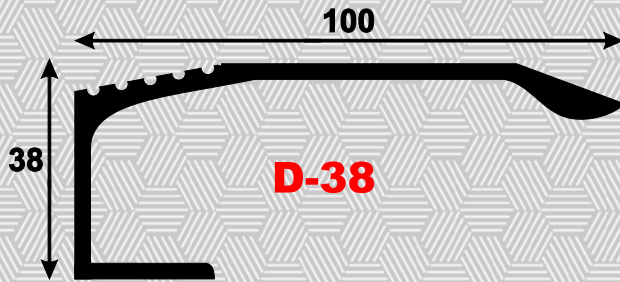

HINGE SECTIONS

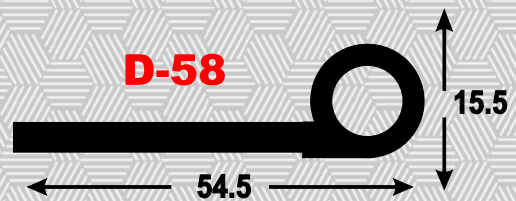
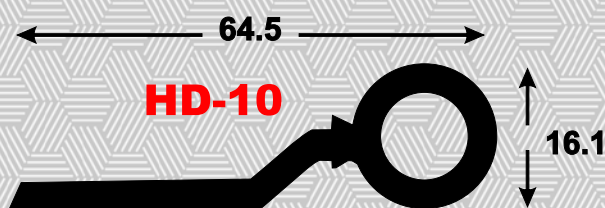
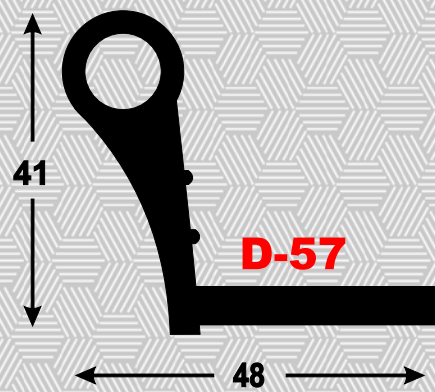



ECONOMY FIXED GLAZING SECTIONS

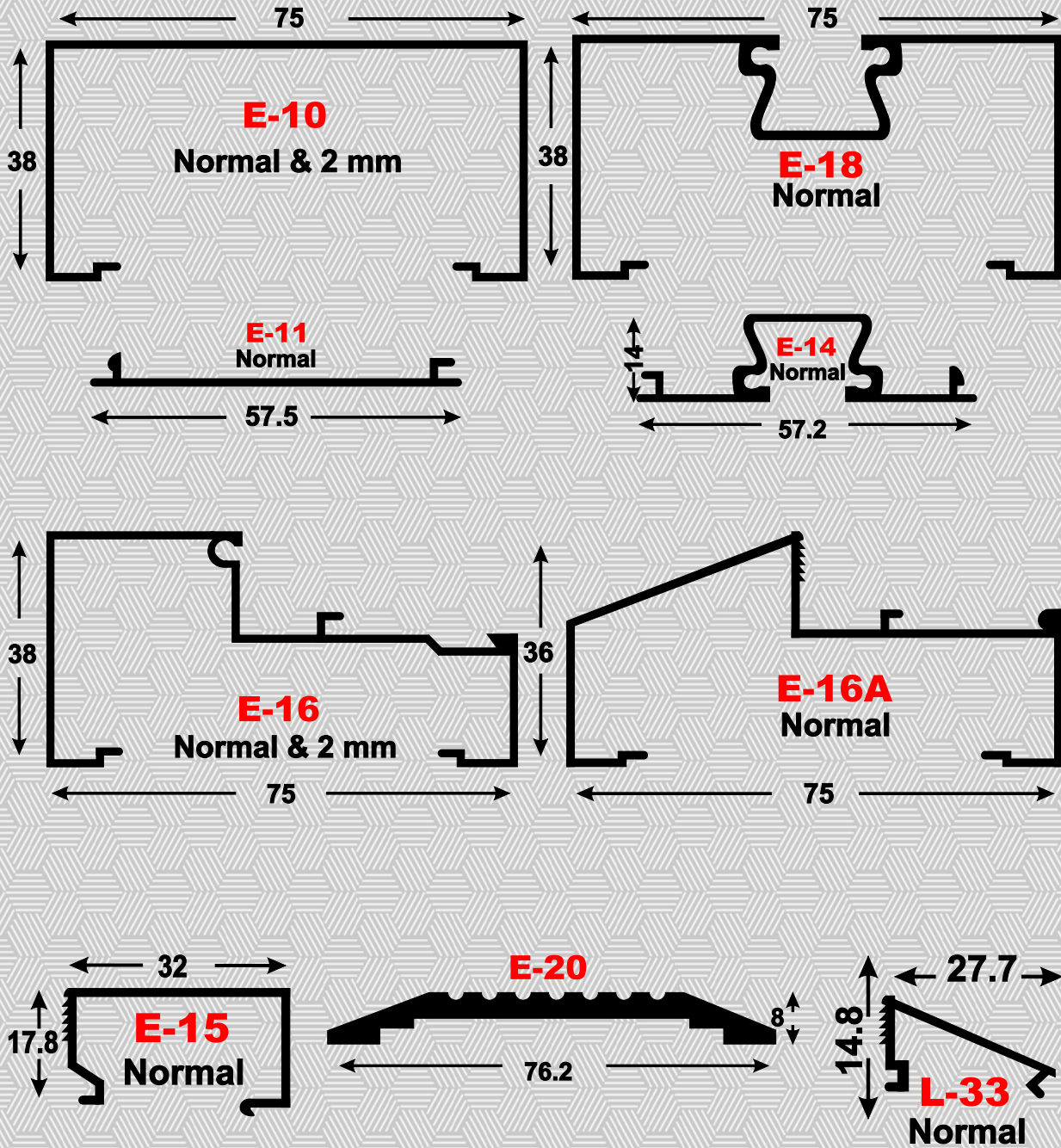



BOX SLIDING WINDOW SECTIONS

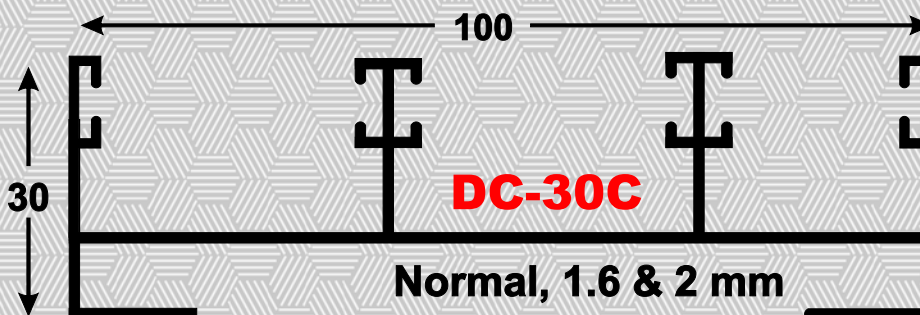
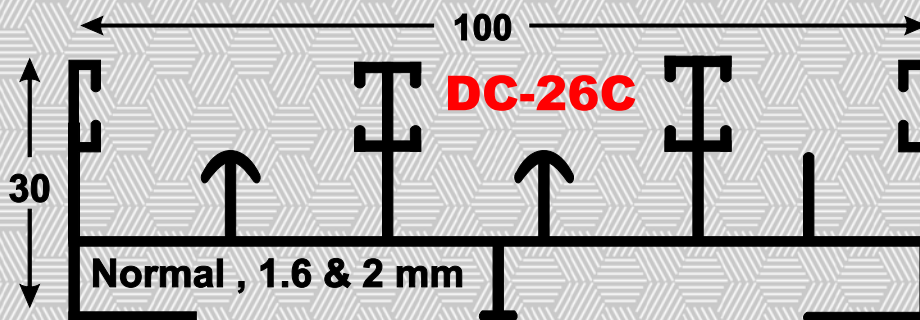
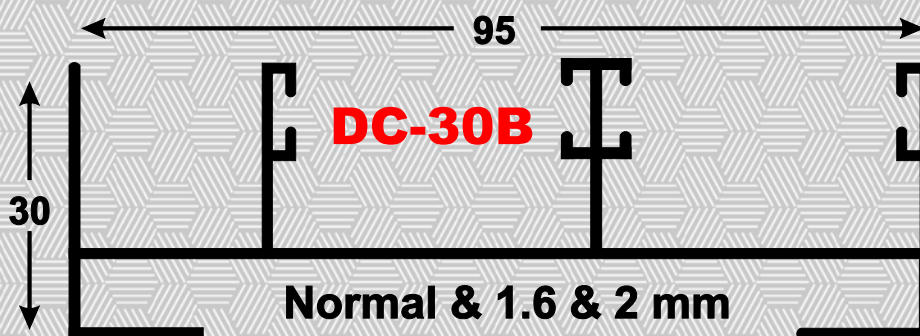
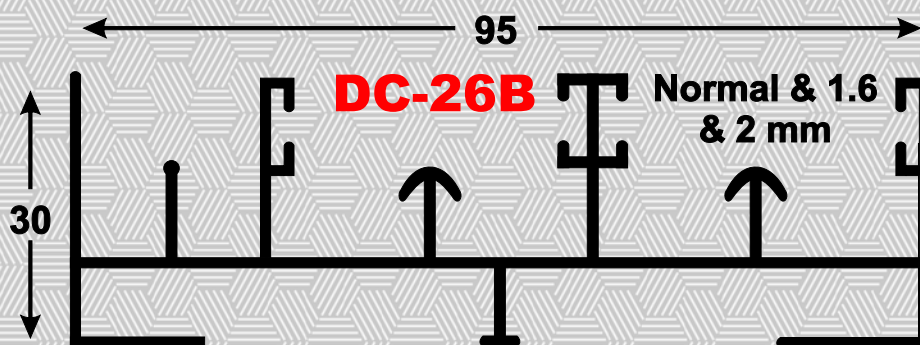

COLLAR BOX SLIDING WINDOW SECTIONS

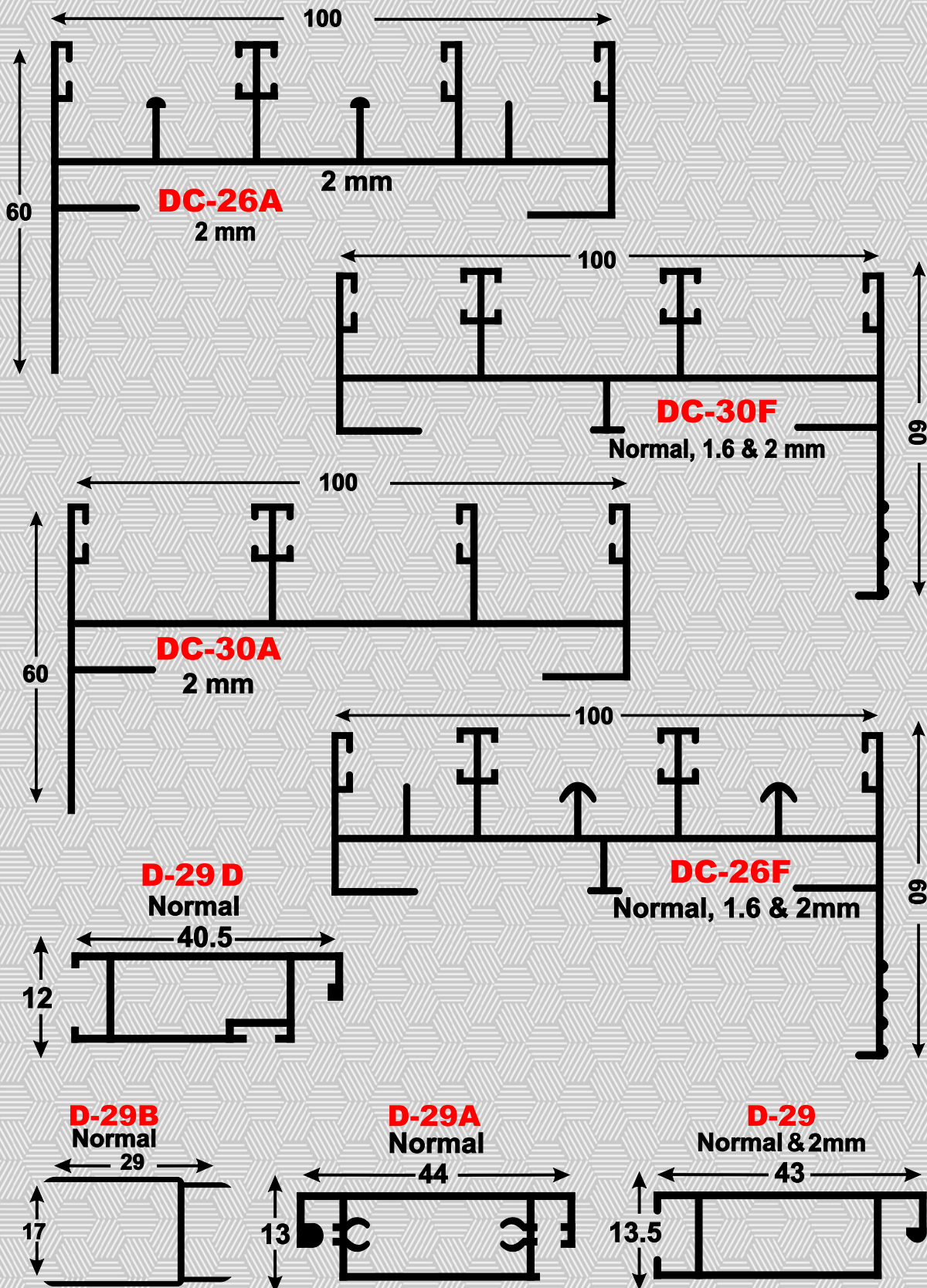

COLLAR 7 ROUND BOX SLIDING WINDOW SECTIONS

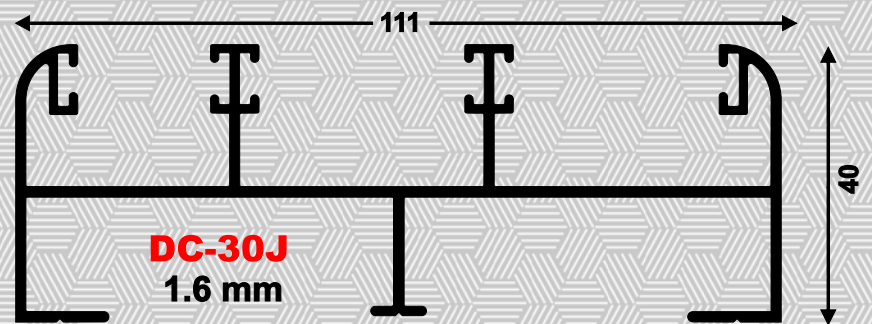
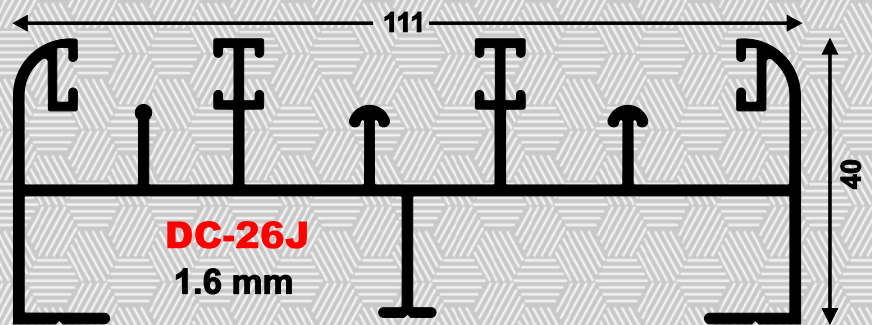
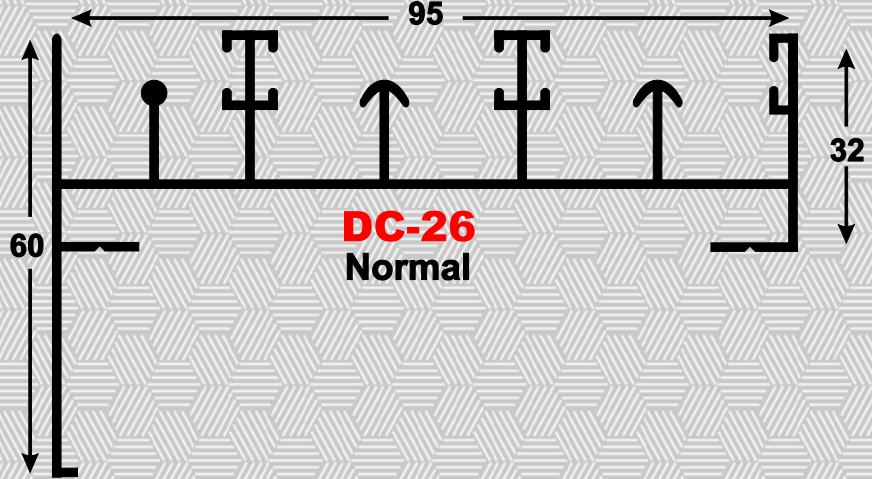
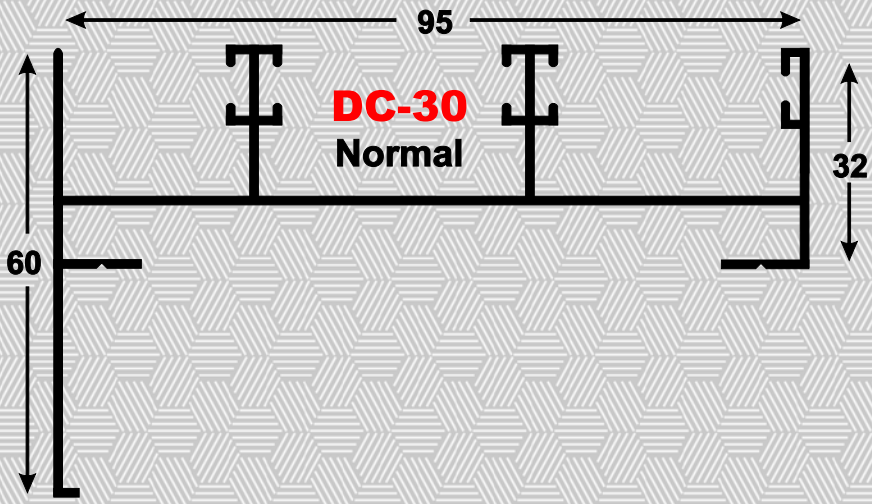

ET ECONOMY SLIDING WINDOW SECTIONS

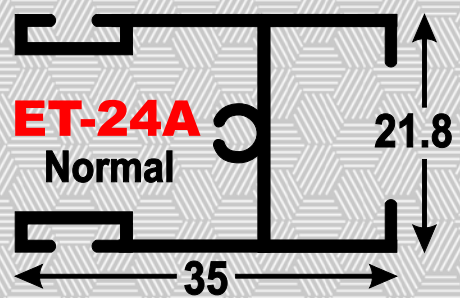
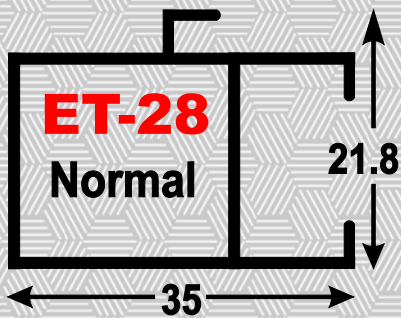
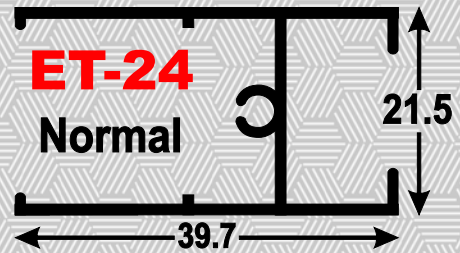
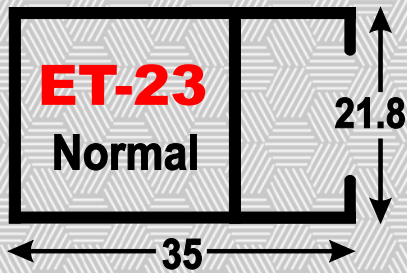
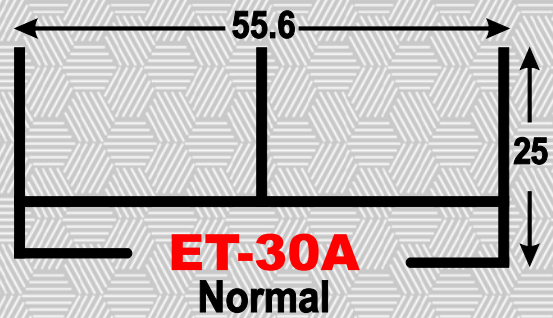
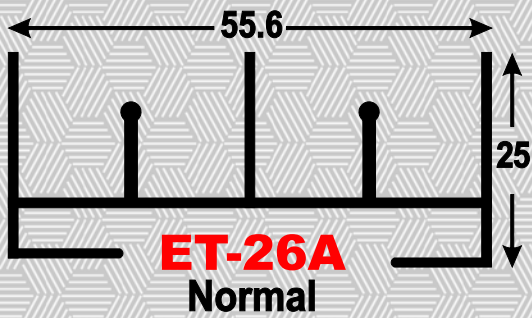
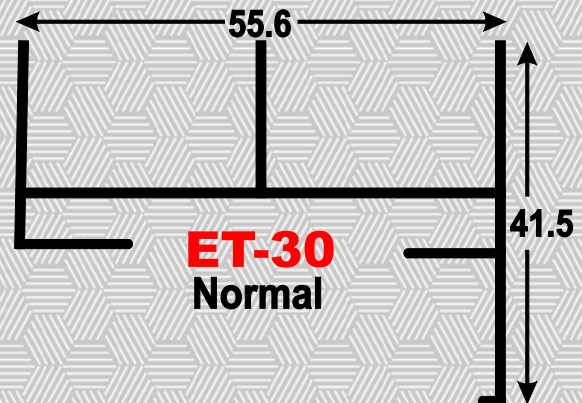
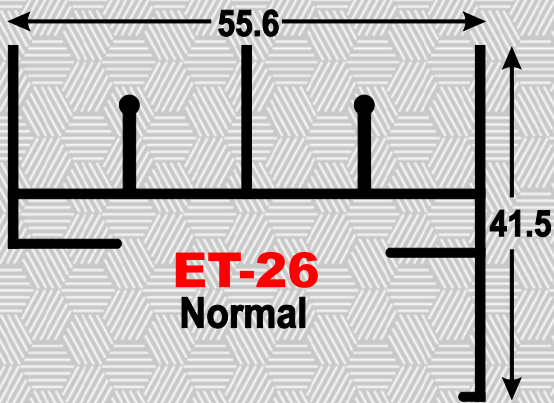



EC ECONOMY SLIDING WINDOW SECTIONS

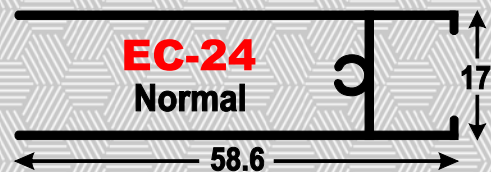
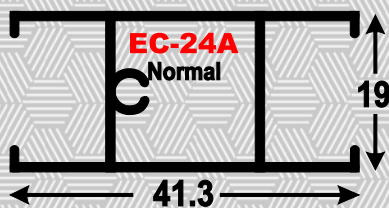
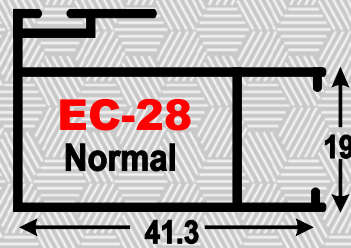
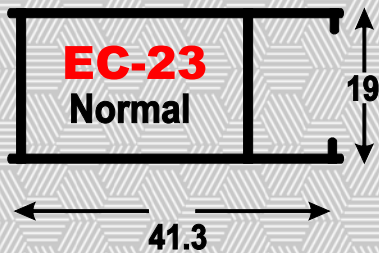
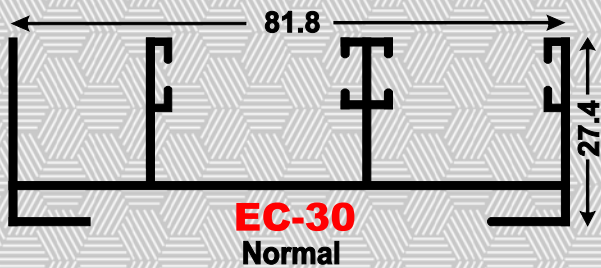
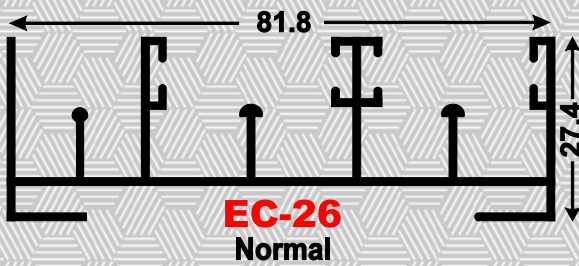
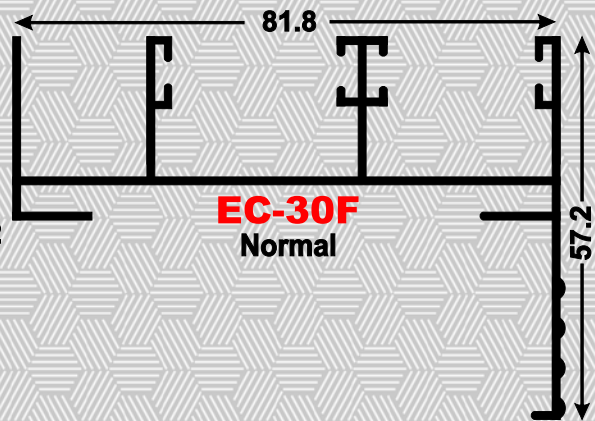
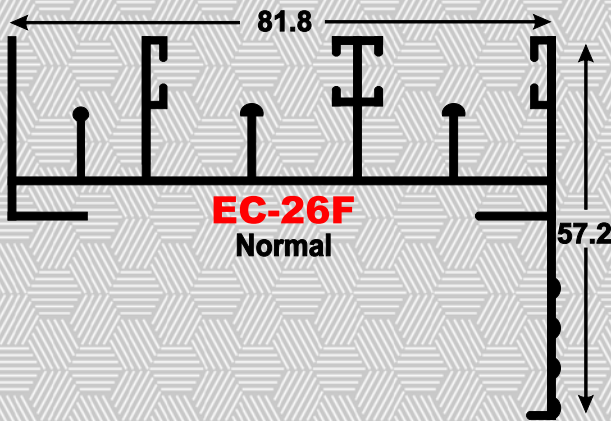



DOOR STRIP SECTIONS

STRIP-1
Normal



STRIP-6
Normal



D-61 A
Normal

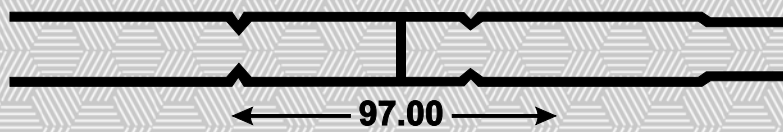

ECONOMY & BOX SLIDING WINDOW SECTIONS

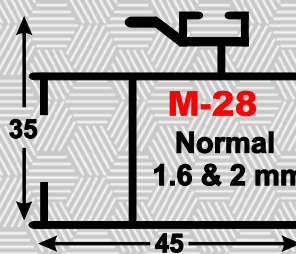
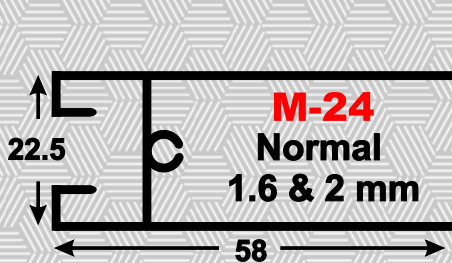
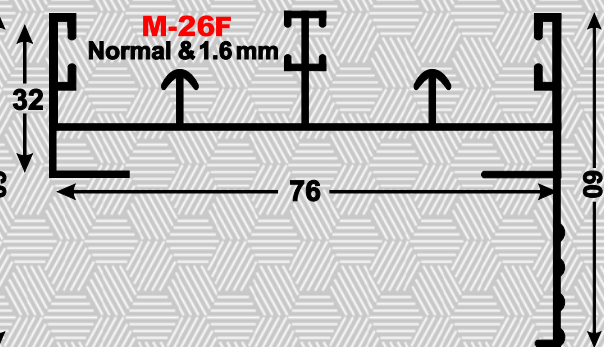
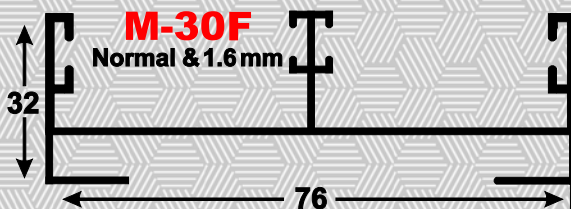
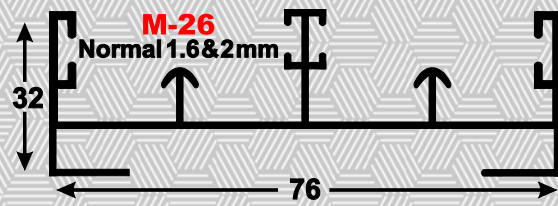
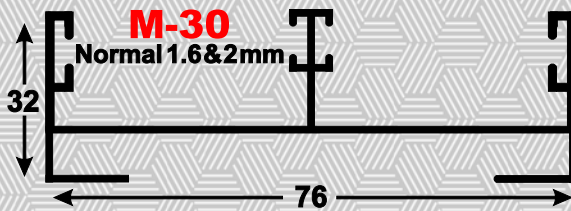



BOX SLIDING WINDOW SECTIONS

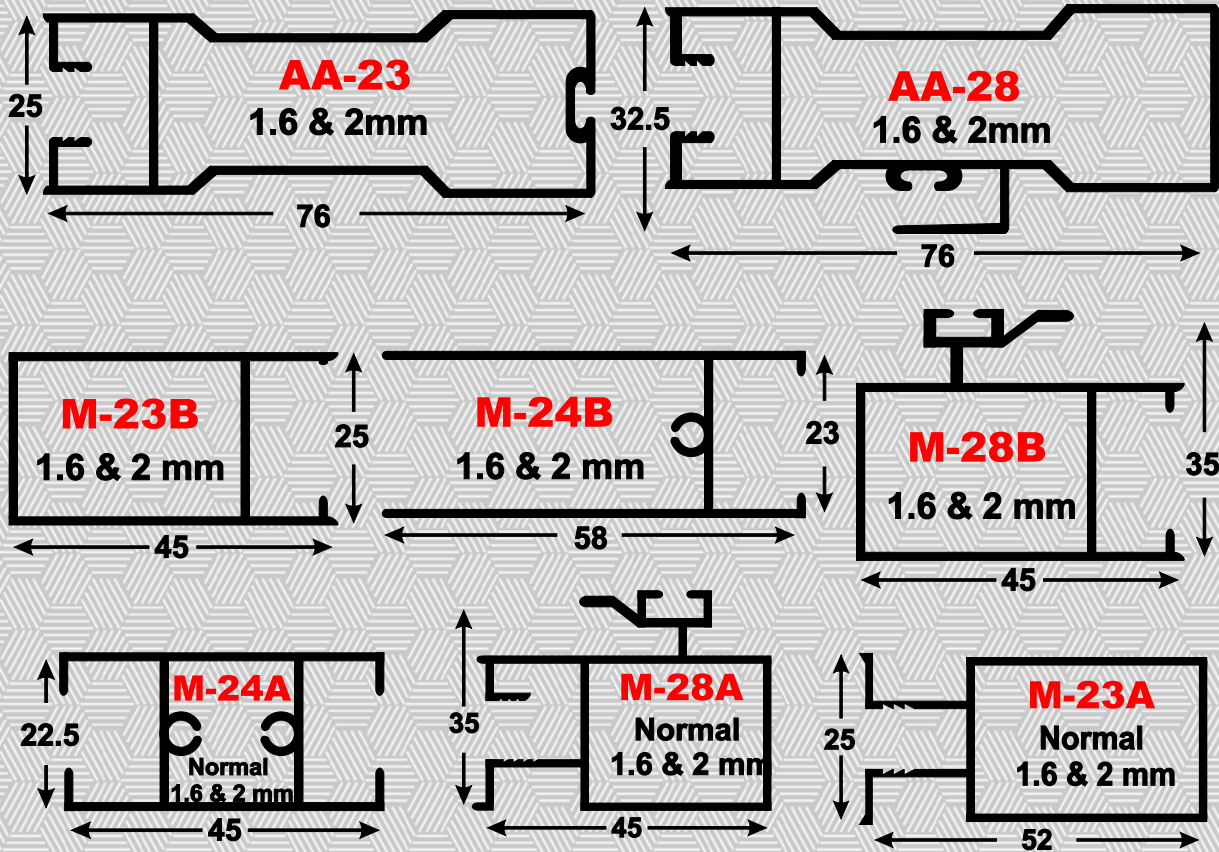

CURTAIN WALL SECTIONS

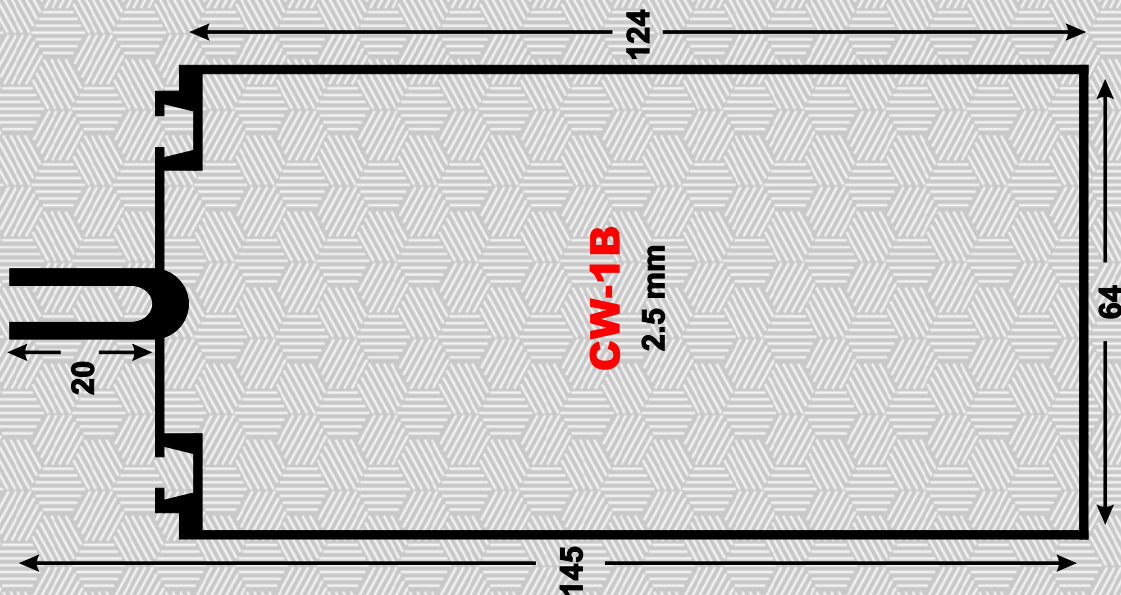

CURTAIN WALL SECTIONS

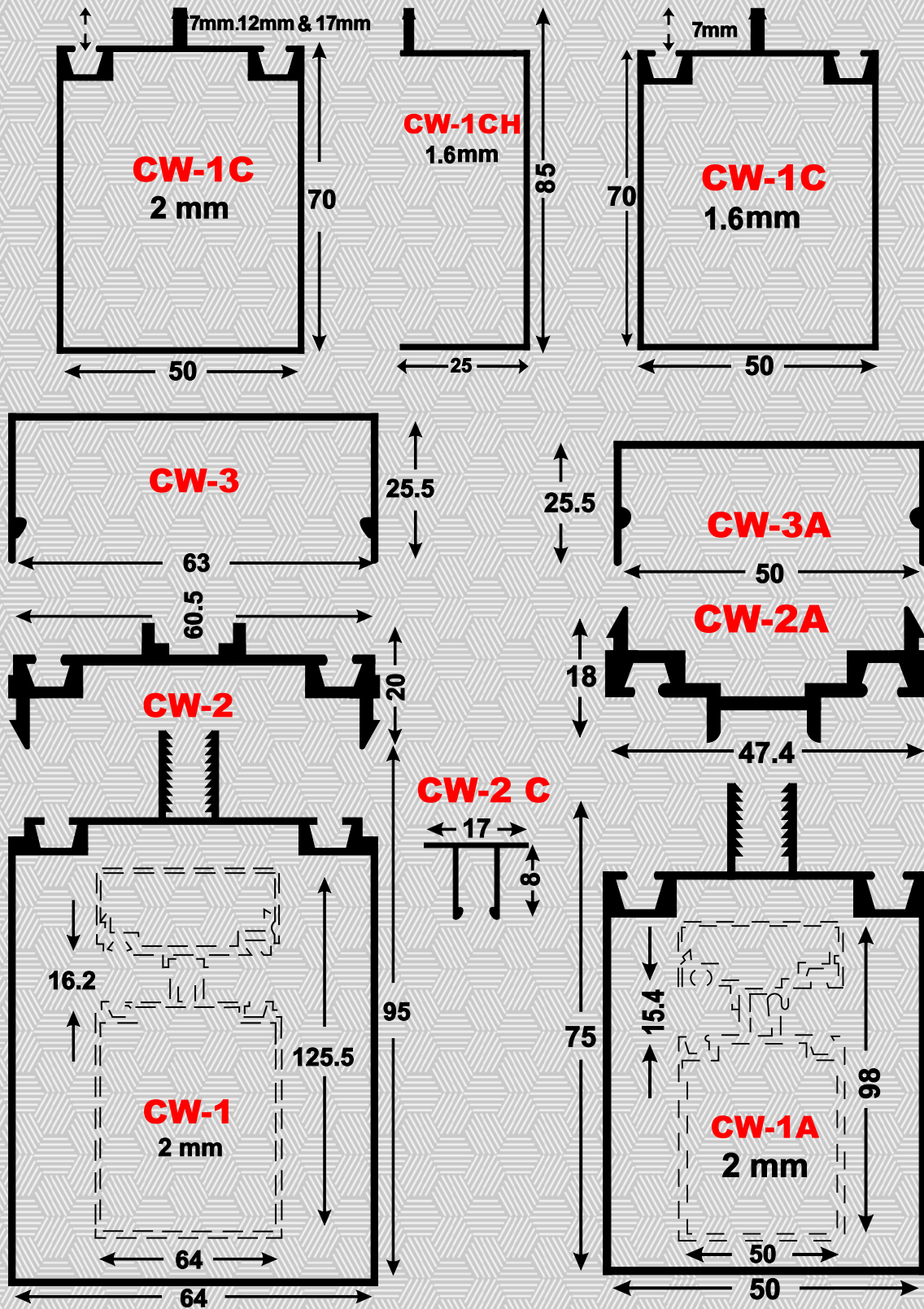

CURTAIN WALL SECTIONS

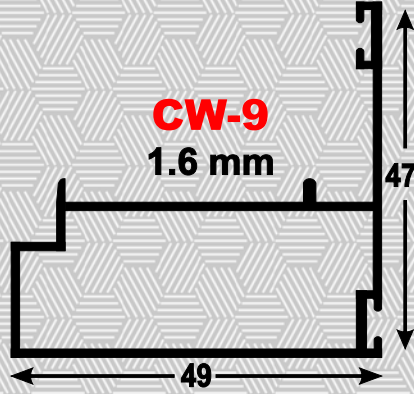
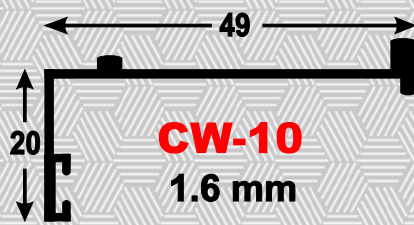
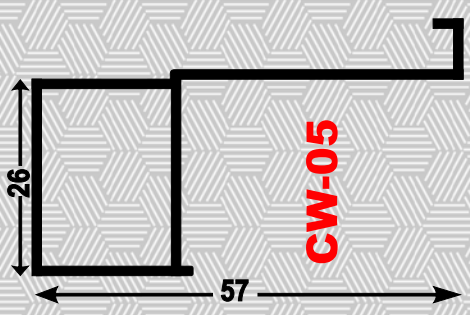
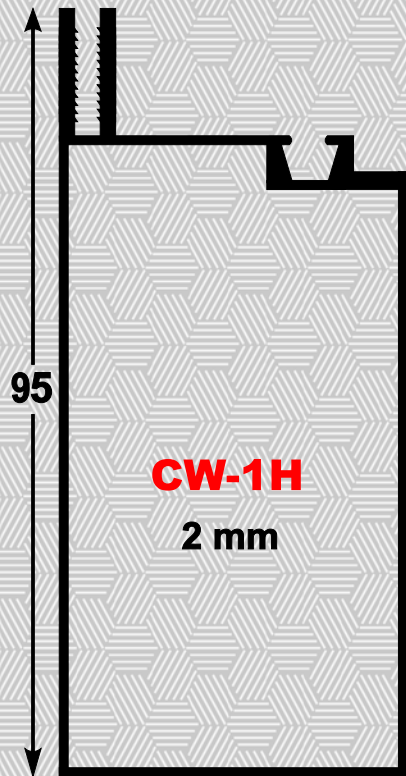
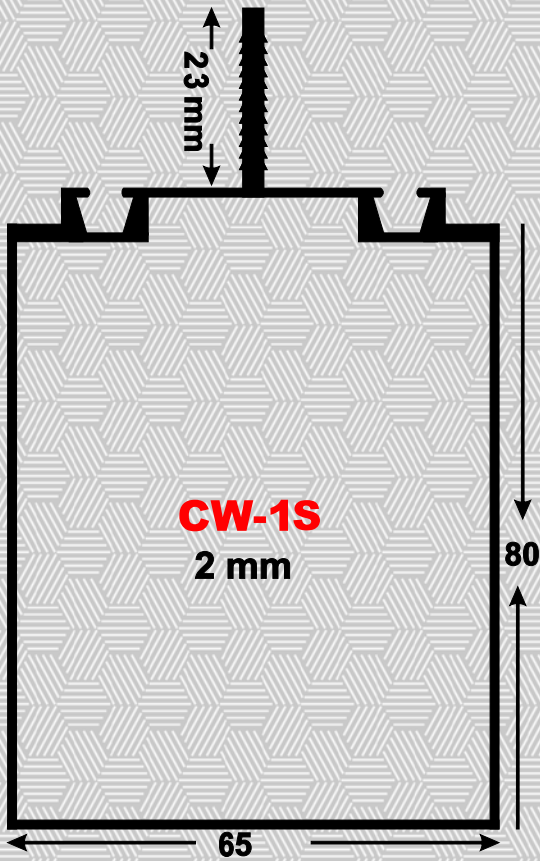

KITCHEN SECTIONS

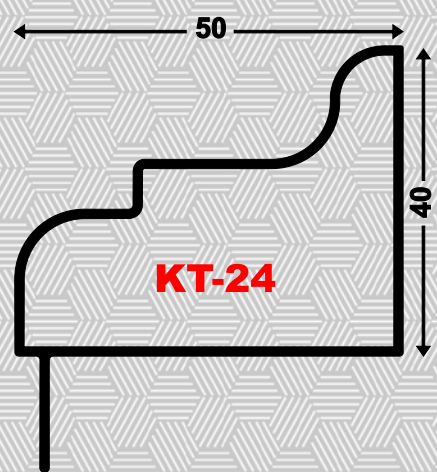
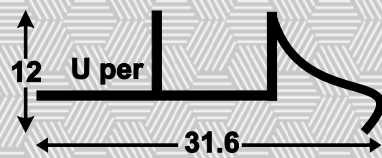
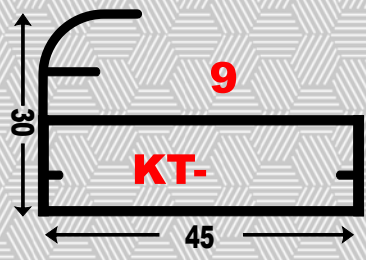
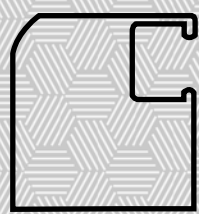
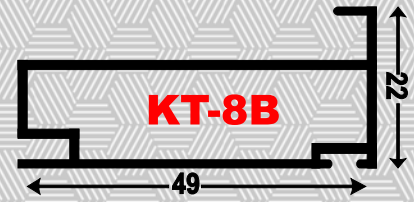
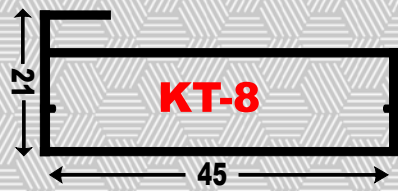
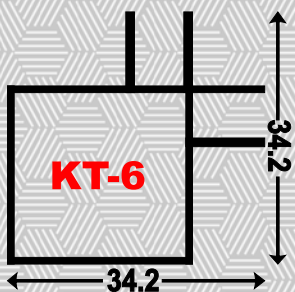
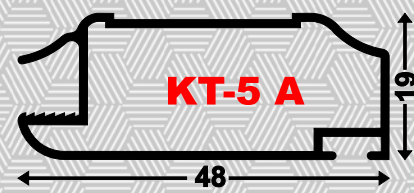
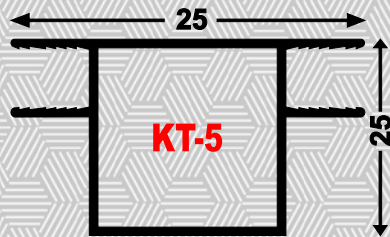
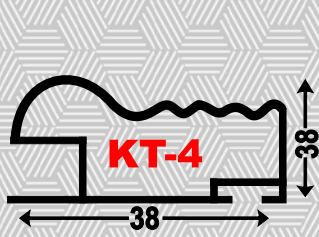
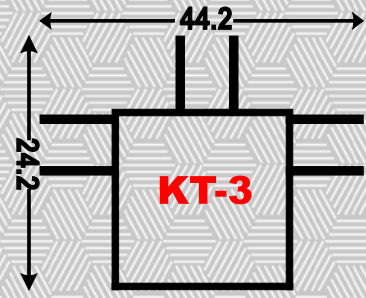
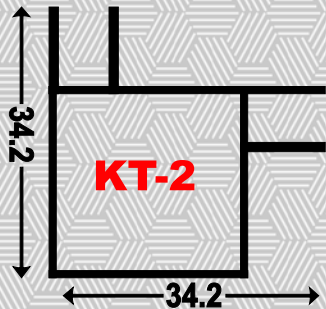
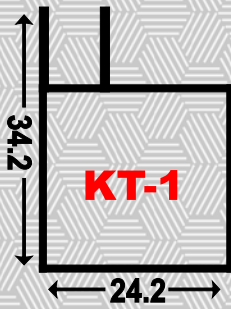

BOX DG WINDOW SECTIONS

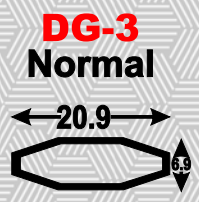
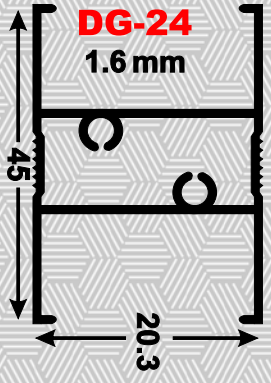
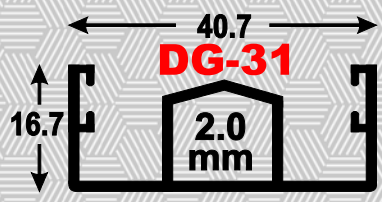
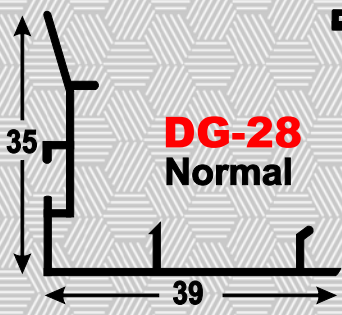
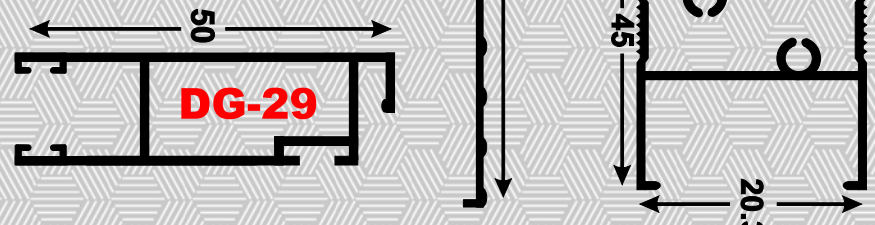
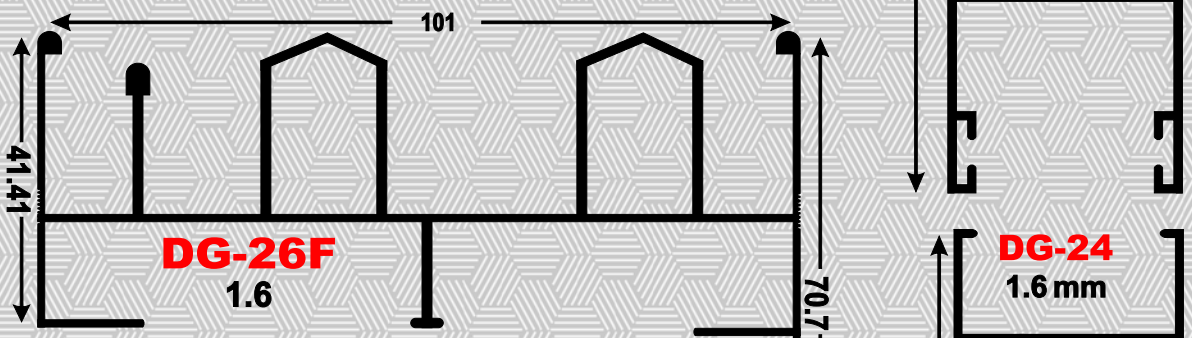
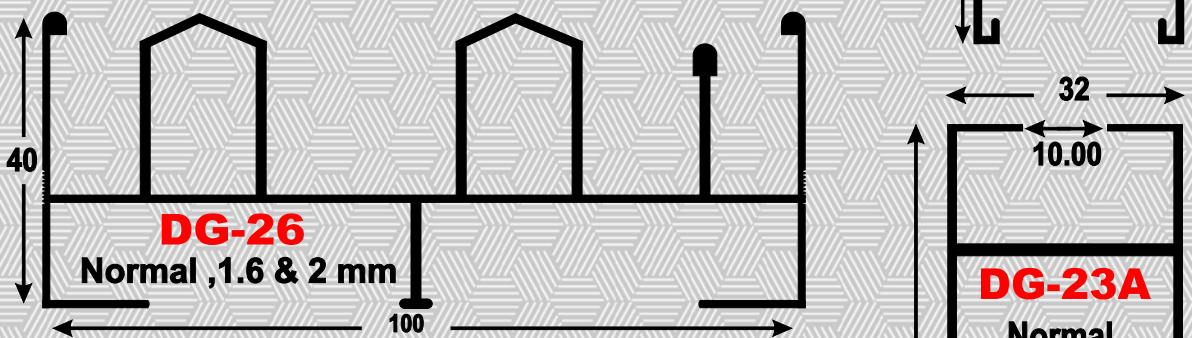
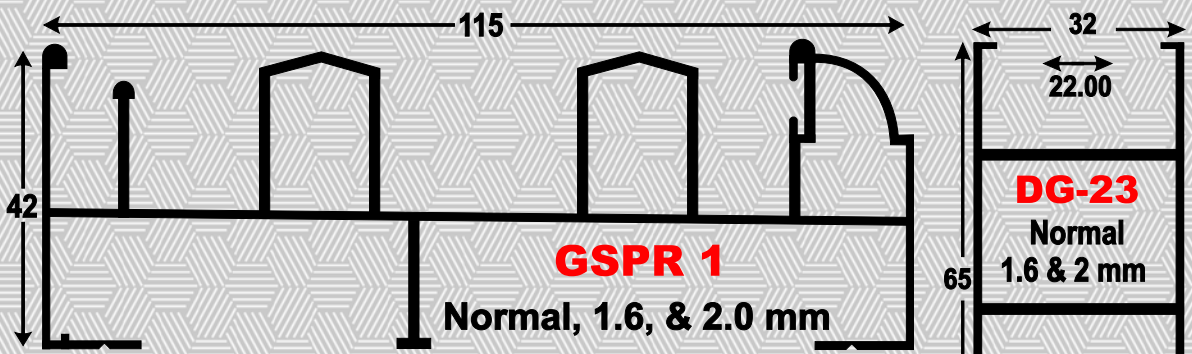



BOX HD FIX & DOOR SECTIONS

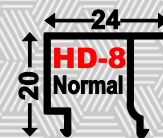
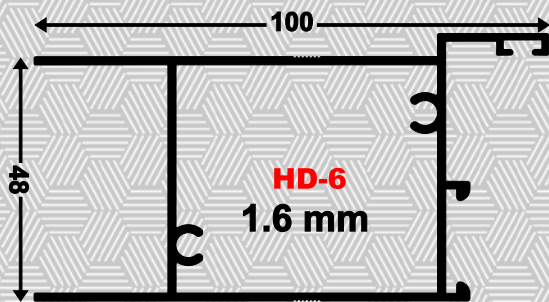
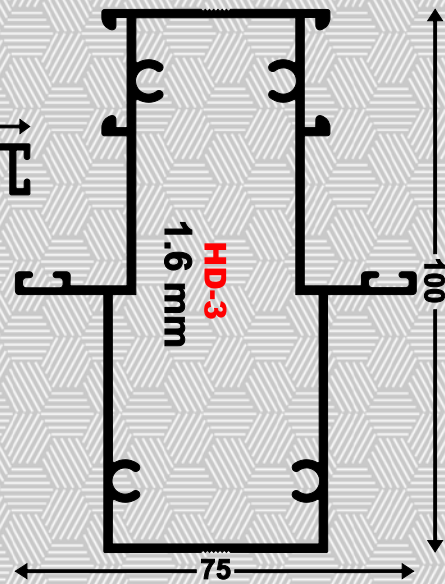
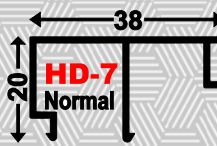
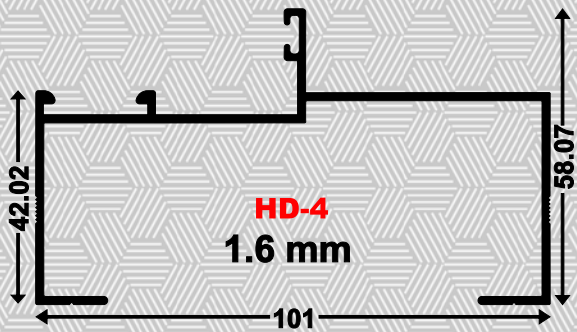
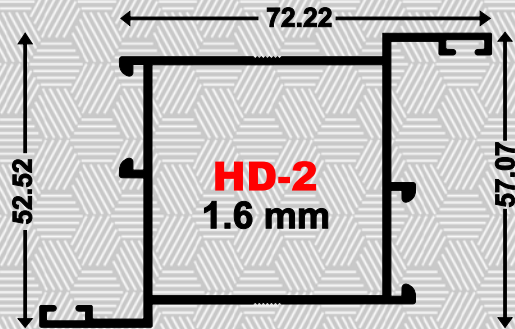
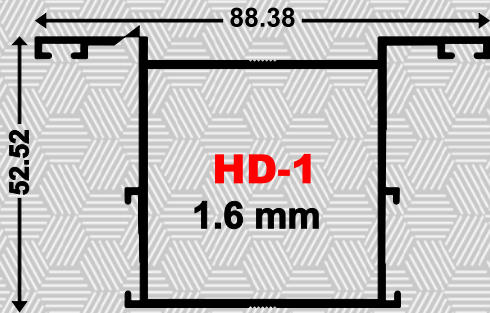

LOWER SECTIONS

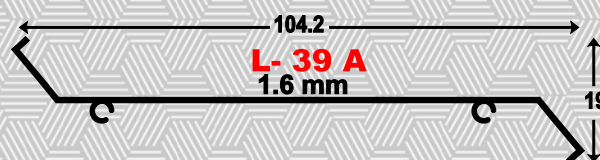
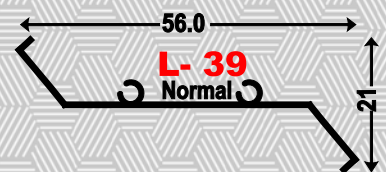
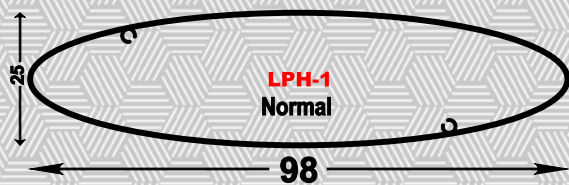



PIPE SECTIONS

1" X 1"
Normal

1" X 2"
Normal, 1.6 & 2 mm

1" X 3"
Normal, & 2 mm

1 1/2" X 1 1/2"
Normal, & 2 mm

1 1/2" X 3"
Normal

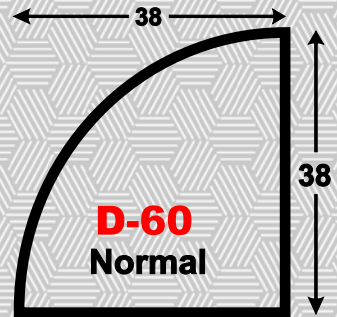

2" X 2"
Normal

2" X 4"
2 mm

1" X 4"
Normal

4" X 4"
2 mm

1 3/4" X 4"
1.6 mm

MISCELLANEOUS SECTIONS

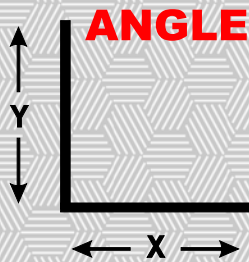
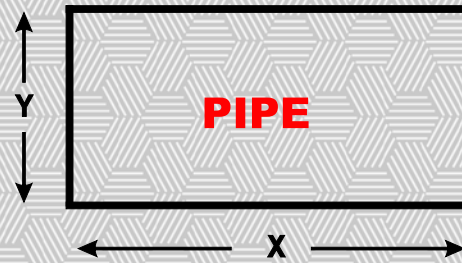
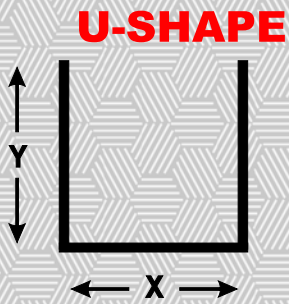
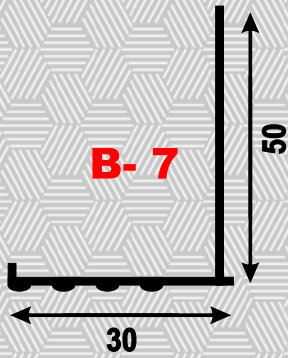
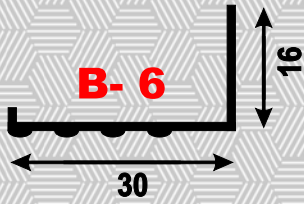

PIPE SIZE

S.No.	SIZE		THICKNESS
	X	Y	T(mm)
1	1	1	1.2 mm
2	1.1/2	1.1/2	1.2 mm
3	1	2	1.2 mm
4	2	2	1.4 mm
5	1	3	1.2 mm
6	1.1/2	3	1.4 mm
7	1	4	1 mm
8	1.3/4	4	1.2, 1.6 mm
9	4	4	2 mm

ANGEL SIZE

S.No.	SIZE		THICKNESS
	X	Y	T(mm)
1	1.1/2	1.1/2	6 mm/3 mm
2	1.1/24	1.1/4	3 mm
3	1	1	3 mm
4	0.3/4	0.3/4	3 mm
U	1	0.3/4	



ITTEHAD
ALUMINIUM INDUSTRIES

**POWDER COATING
&
ALU WOOD COLOR
CHART**



ITTEHAD
ALUMINIUM INDUSTRIES

WARRANTY

We offer Guarantee of 20 Years in any color change in Colors used in our all Powder Coated Products.



POWDER COATING COLORS



 **PE/7/RAL9016**



 **PE/7/RAL13C**



 **PE/7/RAL9001**



 **PE/7/RAL9010**



 **PE/7/RAL1015-M**



 **PE/7/RAL13-TX**



 **PE/7/609/SM**

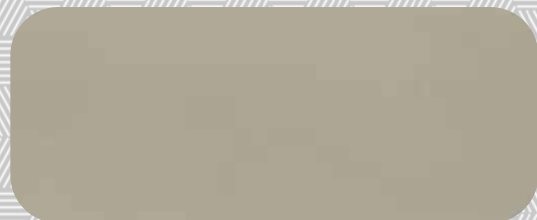

 **PE/7/RAL918-J/P**



 **PE/7/RAL7032-TX**



 **PE/7/RAL7032**

Important Note: The Color in this Chart is just for reference and a slight color variation may occur between different products.



POWDER COATING COLORS



 **PE/7/RAL7339-P**



 **SAHARA BLUE**



 **PE/7/RAL5007**



 **PE/7/RAL5012**



 **PE/7/RAL5013**



 **PE/7/RAL5012-TX**



 **PE/7/RAL5017**



 **PE/7/RAL5018**



 **PE/7/225-G**



 **PE/7/RAL3000**

Important Note: The Color in this Chart is just for reference and a slight color variation may occur between different products.



POWDER COATING COLORS



 **PE/7/CHAMPAGNE/915-M**



 **PE/7/CHAMPAGNE/9647-M**



 **PE/7/RAL7006**



 **PE/7/RAL502-GM**



 **PE/7/RAL7012**



 **PE/7/RAL7024**



 **PE/7/RAL7024-M**



 **PE/7/RAL7001**



 **PE/107-G-METALLIC**



 **PE/7/018-BX**

Important Note:The Color in this Chart is just for reference and a slight color variation may occur between different products.



POWDER COATING COLORS



 **PE/7/RAL6000**



 **PE/7/6002**

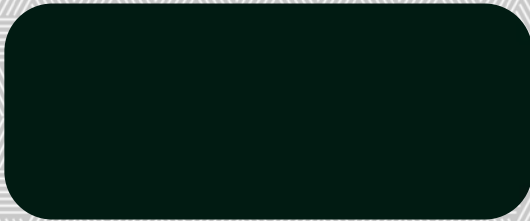

 **PE/7/RAL6005**



 **SAHARA GREEN**

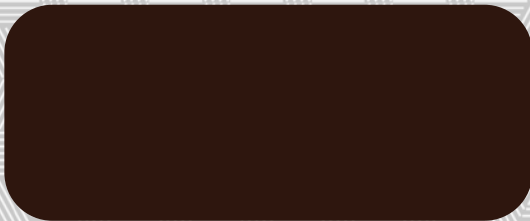

 **PE/7/RAL8017**

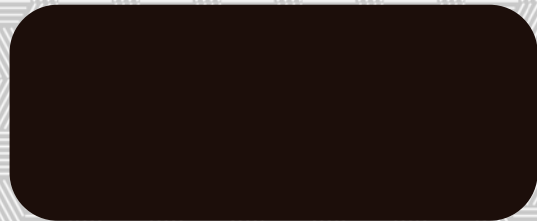

 **PE/7/RAL8019**



 **PE/7/RAL9005-M**



 **PE/7/RAL9005-S**



 **SAHARA BROWN**



 **PE/7/RAL1023**

Important Note: The Color in this Chart is just for reference and a slight color variation may occur between different products.



POWDER COATING COLORS



 **EBONY BLACK**



 **CONCORD**



 **INFINITY WHITE**



 **SPHINX BEIGE**



 **JADE GREEN**

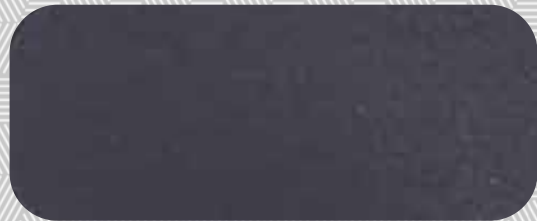

 **ATLANTIS GREY**



 **LAGOON BLUE**



 **AQUA BLUE**



 **SILENT PURPLE**



 **DEEP RED**

Important Note: The Color in this Chart is just for reference and a slight color variation may occur between different products.



POWDER COATING COLORS



 **DIAMOND BLUE**



 **CHAMPAGNE**



 **TITANIUM SILVER**



 **AZTEC GREY**



 **HERITAGE**



 **FIRESTONE**



 **LILAC PURPLE**



 **CORAL GREEN**



 **AZURE BLUE**



 **SAHARA BLACK**

Important Note: The Color in this Chart is just for reference and a slight color variation may occur between different products.



ALU WOOD COLORS



TEAK 1A



TEAK 1



TEAK 2



TEAK 3

Important Note: The Color in this Chart is just for reference and a slight color variation may occur between different products.



ALU WOOD COLORS



PINE 1



PINE 2



CHERRY 1



CHERRY 2

Important Note: The Color in this Chart is just for reference and a slight color variation may occur between different products.



ALU WOOD COLORS



 **COCO 1**



 **COCO 2**



 **TEAK MAROON**



 **TEAK 9135**

Important Note: The Color in this Chart is just for reference and a slight color variation may occur between different products.

EXPO 2017



EXPO2018



EXPO 2019



TAXPAYER REGISTRATION CERTIFICATE

(Under Section 181C of the Income Tax Ordinance 2001)

Registration No. 1806245



1806245

Date of Registration 12-Jan-2004

Type of Person Association of Persons

Formation Date 04-Sep-2003

Name ITTEHAD ALUMINUM INDUSTRIES

Address OFFICE G.T ROAD TARNOOL OPPOSITE, KHAYABAN-E-KASHMIR G-1/5, ISLAMABAD,
Islamabad Islamabad Rural

Tax Office RTO ISLAMABAD

Activity Type Business

This is a computer generated certificate and,
hence, no signatures are required.

Displaying of Taxpayer Registration Certificate is mandatory as
provided under section 181C of Income Tax Ordinance 2001.

This is not a valid evidence of being a "filer" for the purposes of clauses (23A) and (35C)
of sections 2 and 181A of the Income Tax Ordinance 2001.



Date of Print 22-Jan-2021

GOVERNMENT OF PAKISTAN
ISLAMABAD ADMINISTRATION
Islamabad Capital Territory



FORM C
CERTIFICATE OF REGISTRATION
OF FIRM

NO. RF/ICT/ 6130 OF 2003

The Registrar of Firms, Islamabad Capital Territory here by acknowledges the receipt of the statement prescribed by Section 58(I) of the Partnership Act, 1932. The statement has been filed and the name of the firm "M/s .ITTEHAD ALUMINIUM INDUSTRIES, 70, POSH ARCADE, G-9 MARKAZ, ISLAMABAD.

has been entered in the Register of Firms.

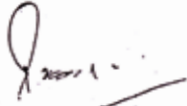

Islamabad :
Dated 4th Sep. 2003.

(CH. MUHAMMAD ALI)
Registrar of Firms,
Islamabad Capital Territory.
REGISTRAR OF FIRMS,
ICT, Islamabad



GOVERNMENT OF PAKISTAN
MINISTRY OF HOUSING AND WORKS
NATIONAL CONSTRUCTION LIMITED

NC House 26 Mauve Area, G-9/1, P.O. Box 1126, Islamabad.

Te: 9106251-53 - Fax: +92-51-9106260

Ref: NC/DGM(N)/2018/452 E-mail: ncl@nayatel.pk

September 25, 2018

TO WHOM IT MAY CONCERN

It is to certify that **M/s Ittehad Aluminum & Co. Islamabad** has been working with this organization as pre-qualified Contractor of NESPAK Projects regarding Aluminum and glass Works and had completed following various Projects under supervision by NESPAK.

1. COMSAT Library Project, Chak Shahzad, Islamabad
2. COMSAT Academic Block (CIIT), Chak Shahzad, Islamabad
3. NUST Institute of Management Sciences (NIMS), Sector H-12 Islamabad
4. NUST Hostel Package-I, Sector H-12 Islamabad
5. NUST Hostel Package-II, Sector H-12 Islamabad
6. Pakistan Planning Management Institute (PPMI), H-8/1 Islamabad
7. Pakistan Institute of Trade & Development (PITAD) H-8/4, Islamabad

M/s Ittehad Aluminum & Co. Islamabad are very dependable Contractor especially at the time of urgency and we are satisfied with their work.

This certificate is issued upon their request.

(SHAHID ANSAR)

Dy. General Manager (North)



Karachi Office: Institution of Engineering Building, Shara-e-Faisal P.O. Box No 8549
Telephones: +91-21-32780243 Fax: +92-21-32780240



Serial No. 1355 Registration No. QP III/E-2/BLDG/13/2012

ENGINEER-IN-CHIEF'S BRANCH CERTIFICATE OF ENLISTMENT/REGISTRATION

M/s ITTEHAD ALUMINIUM INDUSTRIES ISLAMABAD

HAVE BEEN ENLISTED / REGISTERED IN CATEGORY III FOR SUPPLY OF FOLLOWING PRODUCTS

1. Aluminium Profiles/section for DOORS and WINDOWS Joinery	2. _____
3. _____	4. _____
5. _____	6. _____

This Certificate is Valid/Renewed up to 31 Dec 2020

 Brig
 For Engineer-in-Chief
 (Abdul Qudus Khan)

Date 20 Jan 2020

(NON TRANSFERABLE)

P.T.O

- #### TERMS AND CONDITIONS
1. Cost of Enlistment/Registration Form is Rs. 5000.00 (Non-Refundable).
 2. This Enlistment Certificate is valid for the Calendar years only and will be considered cancelled/expired automatically.
 3. The Enlistment Certificate may be renewed on completion of following formalities:-
 - a. A written request for renewal to be submitted two months in advance of expiry period of current certificate.
 - b. A renewal fee of Rs. 10,000/- (Non-Refundable) is to be remitted in the shape of Bank Draft in favour of E-in-C's Branch (DP&W) GHQ, Rawalpindi.
 - c. The current/present certificate in original is to be returned alongwith application for cancellation.
 4. E-in-C is the sole authority to cancel, terminate or issue any Enlistment/Registration against which no appeal lies in any forum.
 5. No claim of any sort shall be admissible consequent to cancellation termination or renewal of Enlistment/Registration.
 6. This Enlistment/Registration is valid for MES, may be considered by other departments.
 7. This Enlistment Certificate is Non-Transferable.



REGISTERED
General Headquarters
Engineer in Chief's Branch
Directorate of Planning & Works
Tel: 9271249
No 2001/Regn/DP&W/Ittehad/E-3
23 Jan 2020

To: HQ DGW&CE (Army) Rawalpindi
HQ DW&CE (Navy) Islamabad
HQ DW&CE (PAF) Chaklala
HQ DW&CE (DP) Rawalpindi
HQ DW&CE (DCI) Islamabad

Information: **M/S Ittehad Aluminum Industries, G.T Road, Tarnol Opposite Khayaban-e-Kashmir, G-15 Islamabad**

Subject: **Enlistment/Registration of Manufacturers/Suppliers for MES**

1. M/S Ittehad Aluminum Industries Islamabad is permanently enlisted as manufacturer-cum-supplier with MES in group **Aluminum** for following product:-
 - a. Aluminum Profiles/Section for Doors and Windows Joinery
2. Enlistment of the firm is valid up to **31 Dec 2020** and will automatically stand cancelled / terminated on the expiry of this date.
3. Relevant data/details of their products/supply items are as under:-
 - a. The products offered conform to National / International Standard Specification No ATM-3-B-487-85 British Specifications BSS-H-19 DTD-372B
 - b. Following guarantee/warranty is offered:-
 - (1) For replacement - **01 Year**
 - (2) For repairs - **01 Year**
 - c. Backup/Repair services. - **10 Years**
 - d. **M/S Ittehad Aluminum Industries Islamabad** has no authorized dealers and will operate directly
 - e. **M/S Ittehad Aluminum Industries Islamabad** are interested in supply on **ALL PAKISTAN BASIS.**
4. All wings/formations undertaking procurement/incorporation of products covered under this letter shall be responsible to ensure the quality of material as per standard specifications claimed to be followed by the manufacturer/supplier. Feedback about performance of firm and the products be fwd to this Dte each year.
5. **Information addressee only** Enlistment certificate bearing serial no. **1385 dated 20 Jan 2020** is enclosed and your registration number will be **DP&W/E-2/BI/dg/15/2012** for future correspondence with all MES formations.
6. Please acknowledge receipt.

Lt Col
Engineer-in-Chief
(H&W) Muhammad Sohab

Encl: **Enlistment Certificate No. 1385 (for information addressee only)**
Distribution:

- | | |
|-----------------------------------|------------------------|
| 1. DW&CE (PMO) C/O JSHQ, Chaklala | 5. DI&E |
| 2. HQ FWO, R A Bazar, Rawalpindi | 6. DD&C |
| 3. MES School, MCE, Risalpur | 7. R&S Dte (Rev Sec) |
| 4. Housing Dte, Rawalpindi | 8. E&M Sec (E-4) Local |



Sr.# 30721



Government of Pakistan
Ministry of Science & Technology

Pakistan Standards & Quality Control Authority (PSQCA)
Technical Services Centre (TSC)

TSC-PSQCA, 125-A, Quaid-e-Azam Industrial Estate, Township, Lahore - 54770, Pakistan

Report No: PSQCA/TSC/DOC/J-78646

Dated: 09.12.2021

Your Ref. # Nil, dated: 30.11.2021, Date of opening of Job. 01.12.2021

TEST REPORT

Name & Address of Client: M/s. Ittehad Aluminium Industries, Islamabad.

Description of Sample(s): Aluminium
(as provided by client)

No. of Samples: 01

Method used/Specs.: ASTM E 92

No. of Sheet: 01

Statement of Non-Compliance: Nil

Temp. & Humidity: -----

Test Results:

Job No.	Test Position/ Location	Scale	Average Hardnes	Converted Hardness
78646	Surface	HV	77.0	70 HB

Chemical Test Results:

Method Used: ASTM E 1251-17

Sr. No.	Job No.	Al%	Si%	Cu%	Fe%	Mg%	Mn%	Zn%	Ti%
01.	78646	98.64	0.39	0.028	0.28	0.53	0.010	0.021	0.011

-----**END OF REPORT**-----

Head
Metallurgical Engg. Division

Engr. Wahab Feroze Din
Director TSC-PSQCA

Ph: +92-42-35213481, 35111804 Fax: +92-42-35122829
Website: www.tsc-psqca.com, E-mail: tscpsqcalhr@gmail.com



PSQCA/TSC/TEC/04-12		
Setup	01	Day 09
Date	30.11.2021	

Sr.# 30777



Government of Pakistan
 Ministry of Science & Technology
Pakistan Standards & Quality Control Authority (PSQCA)
 Technical Services Centre (TSC)
 TSC-PSQCA, 125-A, Quaid-e-Azam Industrial Estate, Township, Lahore - 54770, Pakistan

Report No: PSQCA/TSC/DOC/J-78646

Dated: 09.12.2021

Your Ref. # Nil, dated: 30.11.2021, Date of opening of Job. 01.12.2021

TEST REPORT

Name & Address of Client: M/s. Ittehad Aluminium Industries, Islamabad.

Description of Sample(s): Aluminium
 (as provided by client)

No. of Samples: 01

No. of Sheet: 01

Method used/Specs.: -----

Statement of Non-Compliance: Nil

Temp. & Humidity: -----

Coating Thickness Results:

Job No.	Sample ID	Coating Thickness (Micron) <i>Powder Coating</i>					Factor	Average
		1	2	3	4	5		
78646	1	7.0	7.0	7.0	7.0	7.0	13.2 x 7.0	92.4

END OF REPORT

 Head
 Metallurgical Engg. Division

 Engr. Wahab Feroze Din
 Director TSC-PSQCA

Ph: +92-42-35213481, 35111804 Fax: +92-42-35122829
 Website: www.tsc-psqca.com, E-mail: tscpsqcalhr@gmail.com

For terms and conditions please see overleaf



PSQCA/TSC/457-09-12			
Issue:	01	No.:	00
Date:	August 22, 2019		

Sr.# 30774



Government of Pakistan
Ministry of Science & Technology

Pakistan Standards & Quality Control Authority (PSQCA)
Technical Services Centre (TSC)

TSC-PSQCA, 125-A, Quaid-e-Azam Industrial Estate, Township, Lahore - 54770, Pakistan

Report No: PSQCA/TSC/DOC/J-78649

Dated: 09.12.2021

Your Ref. # Nil, dated: 30.11.2021, Date of opening of Job. 01.12.2021

TEST REPORT

Name & Address of Client: M/s. Ittehad Aluminium Industries, Islamabad.

Description of Sample(s): Aluminium
(as provided by client)

No. of Samples: 01

No. of Sheet: 01

Method used/Specs.: -----

Statement of Non-Compliance: Nil

Temp. & Humidity: -----

Anodizing Thickness Results:

Job No.	Sample ID	Anodizing Thickness (Micron)					Factor	Average
		1	2	3	4	5		
78649	4	2.0	2.0	2.0	2.0	2.0	2 x 6.5	13.0

END OF REPORT

Head
Metallurgical Engg. Division

Engr. Wahab Feroze Din
Director TSC-PSQCA

Ph: +92-42-35213481, 35111804 Fax: +92-42-35122829
Website: www.tsc-psqca.com, E-mail: tscpsqcalhr@gmail.com

For terms and conditions please see overleaf

 G.T. Road, Tarnol, Opp. Khayaban-e-Kashmir
G-15, Islamabad, Pakistan.

 +51 51 222 7683, 222 7684

 +92 51 222 7685

 ittehad_aluminium_industries@hotmail.com

 www.ittehadaluminium.com.pk